

# H-20/35 Pro<sup>TM</sup> Proportioner

311393J

*For spraying polyurethane foam and polyurea coatings.  
Not for use in explosive atmospheres.*



### Important Safety Instructions

Read all warnings and instructions in this manual.  
Save these instructions.

See page 3 for model information, including  
maximum working pressure.

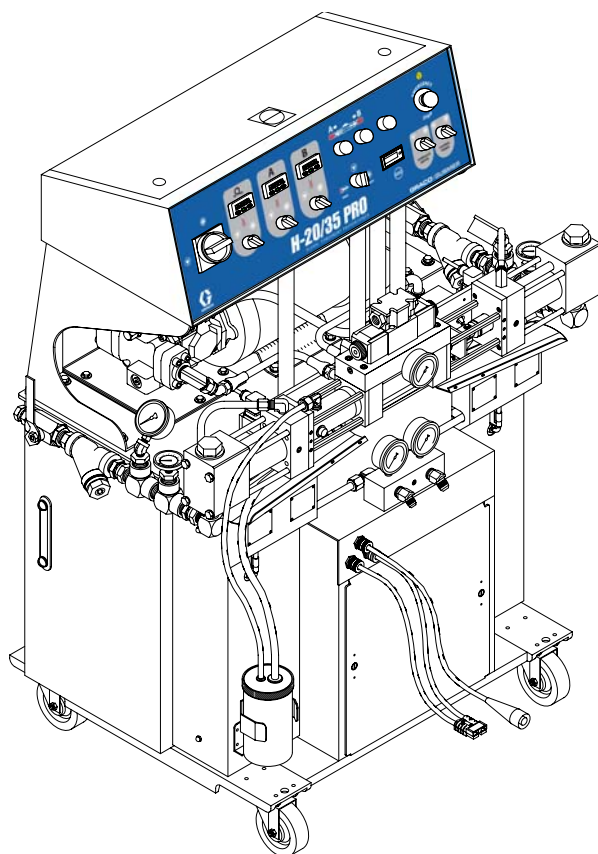

**GRACO | GUSMER**

# Contents

|  |           |
|--|-----------|
| <b>Related Manuals</b> .....           | <b>2</b>  |
| <b>Models</b> .....                    | <b>3</b>  |
| <b>Warnings</b> .....                  | <b>4</b>  |
| <b>Before Beginning Repair</b> .....   | <b>6</b>  |
| <b>Flushing</b> .....                  | <b>6</b>  |
| <b>Pressure Relief Procedure</b> ..... | <b>6</b>  |
| <b>Troubleshooting</b> .....           | <b>7</b>  |
| Primary Heaters .....                  | 7         |
| Proportioning System .....             | 10        |
| Hydraulic Drive System .....           | 13        |
| Hose Heat System .....                 | 14        |
| <b>Repair</b> .....                    | <b>17</b> |
| Primary Heaters .....                  | 17        |
| Proportioning Pumps .....              | 18        |
| Inlet Fluid Strainer Screen .....      | 18        |
| Pump Lubrication System .....          | 19        |
| Hydraulic Drive System .....           | 20        |

|  |           |
|--|-----------|
| <b>Parts</b> .....                     | <b>21</b> |
| Final Assembly .....                   | 21        |
| Base Assembly .....                    | 22        |
| Proportioner Assembly .....            | 23        |
| B-side Heater .....                    | 27        |
| A-Side Heater .....                    | 28        |
| 295027 Hydraulic Cylinder .....        | 29        |
| 296808 Reversing Switch Assembly ..... | 30        |
| Lower Control Box Components .....     | 32        |
| Console .....                          | 33        |
| Electrical Components .....            | 35        |
| <b>Electrical Schematics</b> .....     | <b>38</b> |
| <b>Technical Data</b> .....            | <b>61</b> |
| <b>Graco Standard Warranty</b> .....   | <b>62</b> |
| <b>Graco Information</b> .....         | <b>62</b> |

## Related Manuals

For operation instructions, see manual 311392.

For proportioning pump repair instructions and parts, see manual 312068.







For pump seal repair kit, see manual 312071.







# Models

| Part, Series | Model             | Maximum Working Pressure<br>psi (MPa, bar) | Voltage              | Amps | Total Heater Watts |
|--------------|-------------------|--|----------------------|------|--------------------|
| 295500, A    | H20 Pro           | 2000 (13.8, 138)                           | 230V, 60 Hz, 1 phase | 100  | 12000              |
| 295501, A    | H20 Pro           | 2000 (13.8, 138)                           | 230V, 60 Hz, 3 phase | 60   | 12000              |
| 295502, A    | H20 Pro           | 2000 (13.8, 138)                           | 230V, 60 Hz, 3 phase | 74   | 18000              |
| 295503, A    | H20 Pro           | 2000 (13.8, 138)                           | 380V, 60 Hz, 3 phase | 48   | 12000              |
| 295504, A    | H20 Pro           | 2000 (13.8, 138)                           | 380V, 60 Hz, 3 phase | 62   | 18000              |
| 295505, A    | H20 Pro           | 2000 (13.8, 138)                           | 460V, 60 Hz, 3 phase | 30   | 12000              |
| 295506, A    | H20 Pro           | 2000 (13.8, 138)                           | 460V, 60 Hz, 3 phase | 37   | 18000              |
| 295507, A    | H25 Pro           | 2500 (17.2, 172)                           | 230V, 60 Hz, 1 phase | 100  | 12000              |
| 295508, A    | H25 Pro           | 2500 (17.2, 172)                           | 230V, 60 Hz, 3 phase | 60   | 12000              |
| 295509, A    | H25 Pro           | 2500 (17.2, 172)                           | 230V, 60 Hz, 3 phase | 74   | 18000              |
| 295510, A    | H25 Pro           | 2500 (17.2, 172)                           | 380V, 60 Hz, 3 phase | 48   | 12000              |
| 295511, A    | H25 Pro           | 2500 (17.2, 172)                           | 380V, 60 Hz, 3 phase | 62   | 18000              |
| 295512, A    | H25 Pro           | 2500 (17.2, 172)                           | 460V, 60 Hz, 3 phase | 30   | 12000              |
| 295513, A    | H25 Pro           | 2500 (17.2, 172)                           | 460V, 60 Hz, 3 phase | 37   | 18000              |
| 295514, A    | H35 Pro           | 3500 (24.0, 240)                           | 230V, 60 Hz, 1 phase | 100  | 12000              |
| 295515, A    | H35 Pro, 104 size | 2800 (19.3, 193)                           | 230V, 60 Hz, 1 phase | 100  | 12000              |
| 295516, A    | H35 Pro           | 3500 (24.0, 240)                           | 230V, 60 Hz, 3 phase | 60   | 12000              |
| 295517, A    | H35 Pro, 104 size | 2800 (19.3, 193)                           | 230V, 60 Hz, 3 phase | 60   | 12000              |
| 295518, A    | H35 Pro           | 3500 (24.0, 240)                           | 230V, 60 Hz, 3 phase | 74   | 18000              |
| 295519, A    | H35 Pro, 104 size | 2800 (19.3, 193)                           | 230V, 60 Hz, 3 phase | 74   | 18000              |
| 295520, A    | H35 Pro           | 3500 (24.0, 240)                           | 380V, 60 Hz, 3 phase | 48   | 12000              |
| 295521, A    | H35 Pro           | 3500 (24.0, 240)                           | 380V, 60 Hz, 3 phase | 62   | 18000              |
| 295522, A    | H35 Pro           | 3500 (24.0, 240)                           | 460V, 60 Hz, 3 phase | 30   | 12000              |
| 295523, A    | H35 Pro           | 3500 (24.0, 240)                           | 460V, 60 Hz, 3 phase | 37   | 18000              |



# Warnings

The following general warnings are for the setup, use, grounding, maintenance, and repair of this equipment. Additional, more specific warnings may be found throughout the body of this manual where applicable. *Symbols appearing in the body of the manual refer to these general warnings. When these symbols appear throughout the manual, refer back to these pages for a description of the specific hazard.*



|  <b>WARNING</b>   |   |
|--|---|
|   | <p><b>ELECTRIC SHOCK HAZARD</b></p> <p>Improper grounding, setup, or usage of the system can cause electric shock.</p> <ul style="list-style-type: none"> <li>• Turn off and disconnect power cord before servicing equipment.</li> <li>• Use only grounded electrical outlets.</li> <li>• Use only 3-wire extension cords.</li> <li>• Ensure ground prongs are intact on sprayer and extension cords.</li> <li>• Do not expose to rain. Store indoors.</li> </ul>  |
|   | <p><b>PERSONAL PROTECTIVE EQUIPMENT</b></p> <p>You must wear appropriate protective equipment when operating, servicing, or when in the operating area of the equipment to help protect you from serious injury, including eye injury, inhalation of toxic fumes, burns, and hearing loss. This equipment includes but is not limited to:</p> <ul style="list-style-type: none"> <li>• Protective eyewear</li> <li>• Clothing and respirator as recommended by the fluid and solvent manufacturer</li> <li>• Gloves</li> <li>• Hearing protection</li> </ul>  |
|   | <p><b>TOXIC FLUID OR FUMES HAZARD</b></p> <p>Toxic fluids or fumes can cause serious injury or death if splashed in the eyes or on skin, inhaled, or swallowed.</p> <ul style="list-style-type: none"> <li>• Read MSDS's to know the specific hazards of the fluids you are using.</li> <li>• Store hazardous fluid in approved containers, and dispose of it according to applicable guidelines.</li> </ul>  |
| <br> | <p><b>SKIN INJECTION HAZARD</b></p> <p>High-pressure fluid from gun, hose leaks, or ruptured components will pierce skin. This may look like just a cut, but it is a serious injury that can result in amputation. <b>Get immediate surgical treatment.</b></p> <ul style="list-style-type: none"> <li>• Do not point gun at anyone or at any part of the body.</li> <li>• Do not put your hand over the spray tip.</li> <li>• Do not stop or deflect leaks with your hand, body, glove, or rag.</li> <li>• Do not spray without tip guard and trigger guard installed.</li> <li>• Engage trigger lock when not spraying.</li> <li>• Follow <b>Pressure Relief Procedure</b> in this manual, when you stop spraying and before cleaning, checking, or servicing equipment.</li> </ul> |

|  <b>WARNING</b> |  |
|--|--|
|                 | <p><b>FIRE AND EXPLOSION HAZARD</b></p> <p>Flammable fumes, such as solvent and paint fumes, in <b>work area</b> can ignite or explode. To help prevent fire and explosion:</p> <ul style="list-style-type: none"> <li>• Use equipment only in well ventilated area.</li> <li>• Eliminate all ignition sources; such as pilot lights, cigarettes, portable electric lamps, and plastic drop cloths (potential static arc).</li> <li>• Keep work area free of debris, including solvent, rags and gasoline.</li> <li>• Do not plug or unplug power cords, or turn power or light switches on or off when flammable fumes are present.</li> <li>• Ground all equipment in the work area. See <b>Grounding</b> instructions.</li> <li>• Use only grounded hoses.</li> <li>• Hold gun firmly to side of grounded pail when triggering into pail.</li> <li>• If there is static sparking or you feel a shock, <b>stop operation immediately</b>. Do not use equipment until you identify and correct the problem.</li> <li>• Keep a fire extinguisher in the work area.</li> </ul>  |
|                 | <p><b>PRESSURIZED ALUMINUM PARTS HAZARD</b></p> <p>Do not use 1,1,1-trichloroethane, methylene chloride, other halogenated hydrocarbon solvents or fluids containing such solvents in pressurized aluminum equipment. Such use can cause serious chemical reaction and equipment rupture, and result in death, serious injury, and property damage.</p>  |
|                | <p><b>EQUIPMENT MISUSE HAZARD</b></p> <p>Misuse can cause death or serious injury.</p> <ul style="list-style-type: none"> <li>• Do not operate the unit when fatigued or under the influence of drugs or alcohol.</li> <li>• Do not exceed the maximum working pressure or temperature rating of the lowest rated system component. See <b>Technical Data</b> in all equipment manuals.</li> <li>• Use fluids and solvents that are compatible with equipment wetted parts. See <b>Technical Data</b> in all equipment manuals. Read fluid and solvent manufacturer's warnings. For complete information about your material, request MSDS forms from distributor or retailer.</li> <li>• Check equipment daily. Repair or replace worn or damaged parts immediately with genuine Graco (ASM) replacement parts only.</li> <li>• Do not alter or modify equipment.</li> <li>• Use equipment only for its intended purpose. Call your Graco distributor for information.</li> <li>• Route hoses and cables away from traffic areas, sharp edges, moving parts, and hot surfaces.</li> <li>• Do not kink or over bend hoses or use hoses to pull equipment.</li> <li>• Keep children and animals away from work area.</li> <li>• Comply with all applicable safety regulations.</li> </ul> |
|               | <p><b>MOVING PARTS HAZARD</b></p> <p>Moving parts can pinch or amputate fingers and other body parts.</p> <ul style="list-style-type: none"> <li>• Keep clear of moving parts.</li> <li>• Do not operate equipment with protective guards or covers removed.</li> <li>• Pressurized equipment can start without warning. Before checking, moving, or servicing equipment, follow the <b>Pressure Relief Procedure</b> in this manual. Disconnect power or air supply.</li> </ul>   |
|               | <p><b>BURN HAZARD</b></p> <p>Equipment surfaces and fluid that's heated can become very hot during operation. To avoid severe burns, do not touch hot fluid or equipment. Wait until equipment/fluid has cooled completely.</p>  |

## Before Beginning Repair





|  |   |  |  |  |  |  |
|--|---|--|--|--|--|--|
|   |  |  |  |  |  |  |
| <p>Repairing this equipment requires access to parts which may cause electric shock or other serious injury if work is not performed properly. Electrical troubleshooting must be done by a qualified electrician. Be sure to shut off all power to the equipment and lock out power at the source before repairing.</p> |   |  |  |  |  |  |

## Flushing

|  |   |   |  |  |  |  |
|--|---|---|--|--|--|--|
|   |  |  |  |  |  |  |
| <p>Flush equipment only in a well-ventilated area. Do not spray flammable fluids. Do not turn on heaters while flushing with flammable solvents.</p> |   |   |  |  |  |  |

- Flush out old fluid with new fluid, or flush out old fluid with a compatible solvent before introducing new fluid.
- Use lowest possible pressure when flushing.
- To flush entire system, circulate through gun fluid manifold (with manifold removed from gun).
- Always leave some type of fluid in system. Do not use water.

## Pressure Relief Procedure

|   |   |  |   |  |  |  |
|---|---|--|---|--|--|--|
|    |  |  |  |  |  |  |
| <p>Trapped air can cause the pump to cycle unexpectedly, which could result in serious injury from splashing or moving parts.</p> |   |  |   |  |  |  |

1. Select **Park** on Pump Control Switch.
2. Turn off feed pumps.
3. Trigger gun to relieve pressure.
4. Close gun inlet valves.
5. Close fluid supply inlet valves.
6. Service spray gun. See corresponding spray gun manual.

# Troubleshooting

## Primary Heaters



Before performing any troubleshooting procedures:

1. Relieve pressure, page 6.
2. Turn OFF the red main power disconnect.
3. Allow equipment to cool.

### Problems

Try the recommended solutions in the order given for each problem, to avoid unnecessary repairs. Also, determine that all circuit breakers, switches, and controls are properly set and wiring is correct before assuming there is a problem.

| Problem  | Solutions  |
|--|------------|
| Primary heater shuts down, control relay circuit and light de-energizes.   | 1          |
| Primary heater does not heat; red LED on the primary heater controller is on.  | 2, 4, 6, 3 |
| Primary heater does not heat; primary heater controller (O1 light) is not on.  | 4, 5       |
| Primary heater controller displays error code SbEr (sensor break).   | 4, 5       |
| Primary heater heats but red LED on controller is on continuously.   | 4, 6, 3    |
| Primary heater partially heats but red LED on controller is on almost continuously.  | 6, 7, 8    |
| When flow starts, the red LED on the primary heater controller turns on and stays on almost continuously for 30 sec or more. | 6          |

### Solutions

1. **Over Temperature Switch.** The independent over-temperature safety circuit includes a over temperature switch attached to each heater. If the surface temperature of the heater exceeds 230°F (110°C), the safety switch will interrupt the primary heater control contactor circuit, de-energizing that heater's control relay.

Allow the heater to cool to within safe limits, then the safety switch resets the primary heater circuit. Do not reset the circuit more than once. You must determine the cause of the problem and correct it.

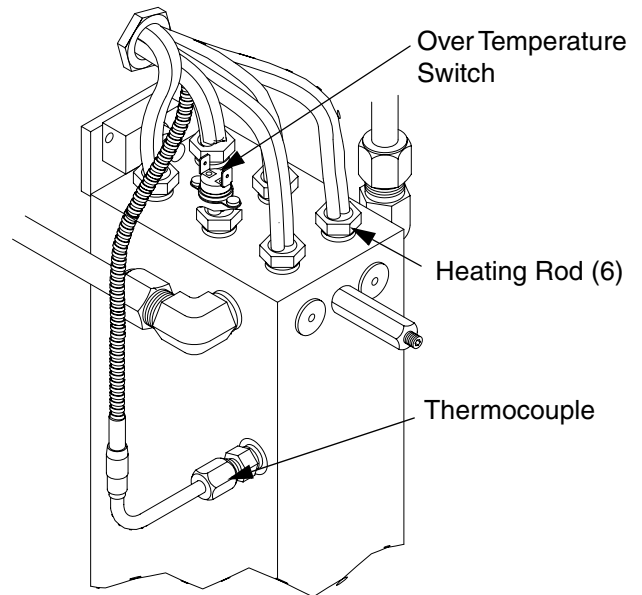

**FIG. 1. Primary Heater**

2. **Primary Heater Circuit Breaker.** With electric power disconnected and locked out at the source, open the console cover. Reset the primary heater circuit breaker if necessary.

Do not reset the circuit breaker more than once. You must determine the cause of the problem and correct it.

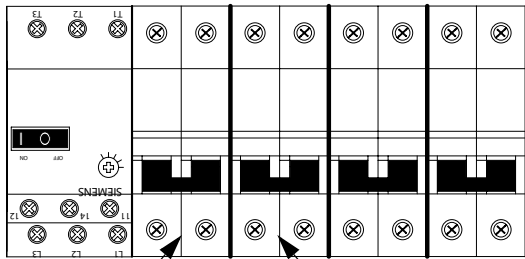

A (ISO) Primary Heater Circuit Breaker      B (Resin) Primary Heater Circuit Breaker

**FIG. 2. Primary Heater Circuit Breakers**

3. **Primary Heater Solid State Relay (SSR).** Checking SSR operation is not possible without electric power. Check the following conditions:
  - a. Check for 5 vdc on terminals 3 and 4 on SSR while 01 red LED output light on the temperature controller is illuminated.

- b. Check for line voltage (230 Vac) between T2 on heater control relay and 2 on SSR while 01 red LED output light on the temperature controller is illuminated.

If all other testing fails to determine the source of the problem, assume the SSR is inoperative and replace it.

4. **Primary Heater Temperature Controller.** The two primary heater controllers are directly interchangeable. To test for a faulty controller, turn OFF the red main power disconnect, and shut off and lock out incoming power at the source. Replace the suspect controller with one known to be good, and retest.
5. **Thermocouple.** The temperature controller will prevent the heaters from operating if there is a signal failure from the thermocouple. If this occurs, replace the thermocouple, page 17. Check for 4-6  $\Omega$  resistance between purple and red wire on the temperature controller, and  $\infty$  infinity  $\Omega$  to ground.

Thermocouple position is critical to proper operation of the heater. Two conditions must be satisfied:

- a. Thermocouple must make contact with the heater cartridge.
- b. Heater cartridge must be functioning properly.

The lack of either of these conditions may cause erratic temperature control and possible overheating. To check thermocouple position, see page 17.



- 6. **Heater Cartridges.** Each heater contains six heater cartridges, wired in parallel. The cartridges in a 6000 W heater are each 1000 W. The cartridges in a 9000 W heater are each 1500 W.

To check operation of the cartridges, measure their combined resistance with an ohmmeter as follows:

- a. **230V 1 phase, 230V 3 phase, and 460V 3 phase units:** With main power OFF, read resistance across terminal #2 on the resin SSR and terminal T2 on the resin heater contactor.

**380V 3 phase units:** With main power OFF, read resistance across terminal #2 on the resin SSR and the blue neutral terminal block.

- b. **230V 1 phase, 230V 3 phase, and 460V 3 phase units:** With main power OFF, read resistance across terminal #2 on the isocyanate SSR and terminal T2 on the isocyanate heater contactor.

**380V 3 phase units:** With main power OFF, read resistance across terminal #2 on the isocyanate SSR and the blue neutral terminal block.

Compare your readings with the combined resistance in Table 1. If your readings are higher, at least one heater cartridge is inoperative. Disconnect the heater cartridges and measure the resistance of each cartridge. The readings should be the same as the resistance per cartridge in Table 1. If not, replace the faulty cartridge(s).

**Table 1. Heater Cartridge Resistance**

| 6000 W Heater       |  | 9000 W Heater       |  |
|---------------------|--|---------------------|--|
| Combined Resistance | Resistance per 1000 W Heater Cartridge | Combined Resistance | Resistance per 1500 W Heater Cartridge |
| 8 ohms              | 48 ohms                                | 5.3 ohms            | 32 ohms                                |

- 7. **Low Line Voltage.** The primary heater is rated at either 6000 W or 9000 W, at 220 V. Low line voltage will reduce power available and the primary heater will not perform at full capability.
- 8. **Ambient Conditions.** The primary heater maximizes heat transfer from available power. However under certain conditions, such as in low temperature environments, the heater cannot maintain the required temperature. This requires moving the unit to a warmer area, reducing flow, or using an auxiliary hose heat system. Contact your Graco distributor for further information.

## Proportioning System



Before performing any troubleshooting procedures:

1. Relieve pressure, page 6.
2. Turn OFF the red main power disconnect.
3. Allow equipment to cool.

### Problems

Try the recommended solutions in the order given for each problem, to avoid unnecessary repairs. Also, determine that all circuit breakers, switches, and controls are properly set and wiring is correct before assuming there is a problem.

| Problem   | Solutions |
|---|-----------|
| Proportioning pump does not hold pressure when stalled. | 1         |
| Pressure imbalance.                                     | 2, 3, 1   |
| Cavitation.   | 3, 2, 1   |
| Pump does not change direction.                         | 4         |
| Pumps do not move, and both directional lights are out. | 6         |
| Erratic pump movement.                                  | 5         |

## Solutions

### 1. Leaking Pump Ball Check Valve.

- Observe gauges to determine which pump is losing pressure.
- Determine in which direction the pump has stalled by observing which directional indicator light is on. See Table 2 to isolate the problem.

**Table 2: Directional Indicator Status**

| Left Pump Directional Indicator Lighted            | Right Pump Directional Indicator Lighted           |
|--|--|
| B-side pump discharge valve (205) dirty or damaged | B-side pump inlet valve (211) dirty or damaged     |
| A-side pump inlet valve (211) dirty or damaged     | A-side pump discharge valve (205) dirty or damaged |

To service the ball check valve:

- a. Turn OFF the red main power disconnect. Shut off and lock out incoming power at the source.
- b. Relieve pressure, page 6.
- c. Close the appropriate fluid inlet supply valve. Disconnect the air supply to the feed pump.
- d. Allow equipment to cool.
- e. A leaking valve is often caused by a foreign particle preventing the ball from seating properly. Remove the appropriate ball guide. Inspect the valve ball and ball seat; flush and wipe clean of all residual material. Inspect the ball seat seal and replace as required.

Using the ball seat removal tool, check the seat for proper seat compression. Snug the seat up to a 1/4 turn maximum.

- If cleaning the ball and seat does not solve the problem, replace the ball, seat, and seal.

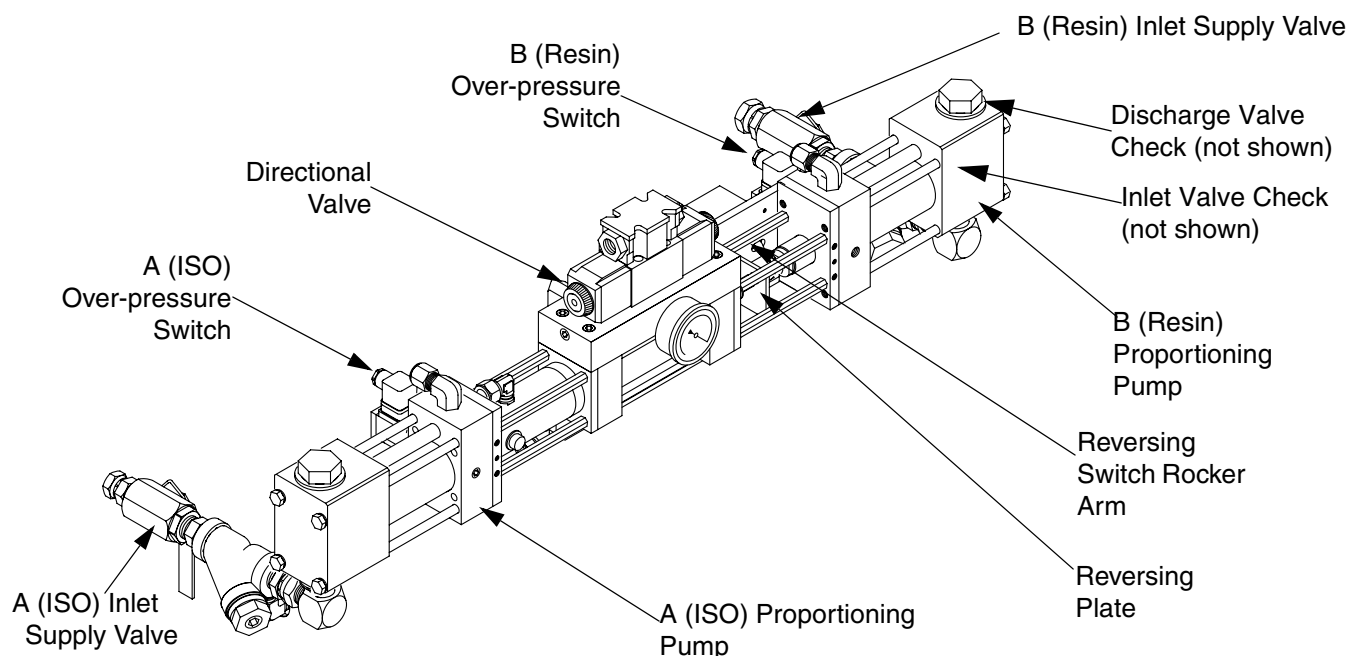

**FIG. 3: Proportioning System**

2. **Pressure/Material Imbalance.** Troubleshooting this problem requires two questions to be answered:

- Which component did not exit the mixing chamber?
- Why did the component fail to get there?

To answer the first question, check the color of the material exiting the gun. Since 2-component foams are usually a combination of light and dark material, the missing or under-proportioned material can be readily determined in most cases.

To answer the second question, observe the pressure gauges on the problem side of the proportioning unit to see if the problem is due to a restriction at the gun or a lack of material produced by the pump. To prevent misinterpretation, focus on the pressure gauge corresponding to the missing component.

*For example:* Assume that B component is not reaching the mixing chamber. Spray off target and note the resin pressure gauge. If the B gauge reads considerably higher than the A gauge, the problem is at the gun. If the B gauge reads considerably lower than the A gauge, see Solution 3.

3. **Cavitation.** Cavitation occurs when the proportioning pump demands a greater volume of material than the supply system can deliver. The most common causes are:

- a. The transfer pump cannot handle the required supply or is malfunctioning. A 2:1 transfer pump is recommended. The supply hose should be 3/4 in. (19 mm) ID minimum, and as short as practical.
- b. Material is too thick for the transfer pump to pump. Consult your material supplier for the recommended material temperature to maintain a viscosity of 250 to 1500 centipoise.
- c. Inlet strainer screen is clogged. See page 18.
- d. A worn pump inlet valve ball/seat or seal. This will allow material to leak past the inlet valve and flow back toward the supply drum. Therefore, the pump will not dispense the proper volume on the discharge stroke and an off-ratio condition will result. This malfunction appears almost identical at the gun.

4. **Reversing Malfunction.** For the proportioning pumps to reverse direction, the activator plate must contact the rocker arm to activate the reversing switch. Failure of the activator plate to make proper contact is usually caused by a bent or loose activator plate or reversing switch.

If the above is not the cause, the failure is likely caused by a loose piston packing retaining bolt. This causes the piston to contact the inner face of the pump inlet flange before the activator plate contacts the rocker arm. To solve this, shut down the unit and disassemble the appropriate pump for repair.

If the activator plate contacts the rocker arm but the directional valve fails to shift, the activator plate will overrun the rocker arm and stop. When this happens, first relocate the activator plate so that it is in the center of the rocker arm as follows:

- a. Turn the pump switch OFF and restore electrical power.
- b. Determine the direction the plate must move; this depends on which stroke is overrun.
- c. On the hydraulic manifold, locate the manual operator coil, which is located on the same side of the machine where the activator plate must travel. For example, if the plate overran to the left and requires moving it to the right, toward the resin pump, the manual operator on the resin side of the directional valve is the one to activate.

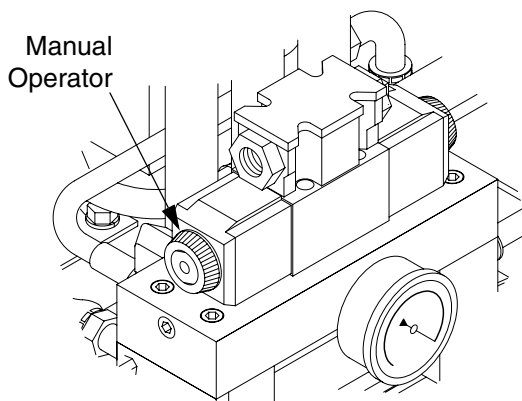

**FIG. 4. Hydraulic Manifold**

Turn ON the main disconnect control power and hydraulic motor control switches. Turn OFF the pump switch and bleed material pressure to zero. With the coupling block manual valves open and pointed into a suitable waste container, push in the manual operator using a 3/16 Allen wrench, and hold it in until the activator plate is approximately centered. Release it when properly positioned and close the gun or coupling block.

If the spool seemed to move freely when pushed, the cause of the overrun was probably an electrical problem. Turn off the hydraulic motor and place the pump switch in the NORMAL position. Push in each end of the rocker arm, listen for the shifting of the spool, and note the directional indicators light up appropriately. If the spool does not shift, or the indicators do not light, there is an electrical problem with the reversing switch, latching relay, directional valve coil, or pump switch.

Should the spool hang up or be hard to push, it is likely that there is a mechanical problem within the directional valve, which will require shutting down the unit and disassembling the directional valve for service.

5. **Over-Pressure Protection.** Each proportioning pump contains a pressure switch set to 200 psi higher than the pump pressure rating. Upon reaching this pressure, the switch will automatically open, causing the pumps to stop and both directional indicator lights to go off. This indicates an open circuit condition. As this is a non-lockout type of system, the proportioning pumps will resume operation when the pressure bleeds off below the preset limits. However the cause of the over-pressure condition should be determined and corrected. The three most likely causes are:

- a. A restriction in the gun on the high pressure side.
- b. Cavitation of the opposite pump.
- c. Hydraulic pressure set too high.

6. **Optional Equipment.** The machine is wired to allow for optional equipment interfacing with the machine control circuit. Ensure all jumpers are in place when optional equipment is not installed.

# Hydraulic Drive System



Before performing any troubleshooting procedures:

1. Relieve pressure, page 6.
2. Turn OFF the red main power disconnect.
3. Allow equipment to cool.

## Problems

Try the recommended solutions in the order given for each problem, to avoid unnecessary repairs. Also, determine that all circuit breakers, switches, and controls are properly set and wiring is correct before assuming there is a problem.

| Problem  | Solutions |
|--|-----------|
| Electric motor will not start or stops during operation. ★ See Note in Solution 1. | 1         |
| Hydraulic pump does not develop pressure.  | 2         |
| Low or zero pressure with screeching noise.  | 2, 3      |

## Solutions

1. **Motor Circuit Protector.** The motor circuit protector is set to trip when the electric motor draws too much current. To restore the motor to operation, switch OFF and lock out incoming power at the source, and allow the motor to cool. Reset the motor circuit protector to ON.

Check MCR power on light. Ensure it's illuminated and operating.

| <b>CAUTION</b>   |
|--|
| Always determine and correct the cause of a tripped motor circuit protector. |

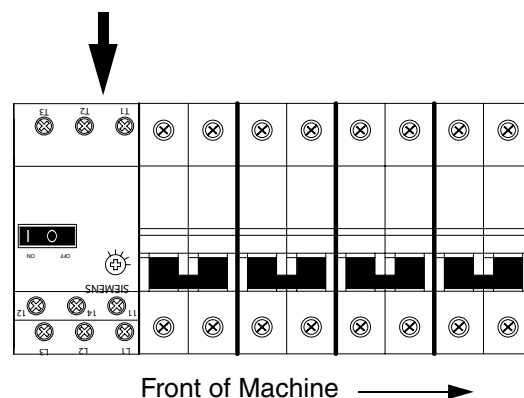

**FIG. 5. Motor Circuit Protector**

2. **Zero or Low Pressure.** Note that hydraulic pressure cannot be generated when the hydraulic motor switch or pump switch is in the OFF position.

Assuming the pump is in proper working order, and the pump switch is set to NORMAL, the major cause of the pump's failure to produce pressure is that it is either not primed or loses its prime. To ensure a positive prime, check the following:

- a. Check electric motor rotation. See **Main Power Installation** in the **Operation** manual.
  - b. Check that hydraulic reservoir is filled to the proper level (halfway up the temperature/level gauge on the right side).
  - c. Check that the pump case is filled with hydraulic fluid.
  - d. Check that inlet fitting is fully tight to ensure no air is leaking into the pump case.
3. **Screeching.** A screeching noise is characteristic of cavitation and is normal at initial startup for a maximum of 30 seconds. If the screeching continues for more than 30 seconds, switch off the pump switch and hydraulic motor switch and check that the inlet fittings are tight and that the pump has not lost its prime.

A second cause of screeching can be excessive hydraulic oil temperature. Determine that the reservoir is properly serviced and if necessary provide better ventilation to permit the reservoir to dissipate heat more efficiently.

## Hose Heat System



Before performing any troubleshooting procedures:

1. Relieve pressure, page 6.
2. Turn OFF the red main power disconnect.
3. Allow equipment to cool.

### Problems

Try the recommended solutions in the order given for each problem, to avoid unnecessary repairs. Also, determine that all circuit breakers, switches, and controls are properly set and wiring is correct before assuming there is a problem.

| Problem   | Solutions        |
|---|------------------|
| Hose warms but does not reach temperature or takes too long to reach temperature. | 1, 8             |
| Hose does not heat.   | 2, 3, 4, 5, c, 9 |
| Hose heat controller displays alternating SbEr and H2000 code.                    | c                |
| Hose heat controller displays all other error codes.                              | 4                |
| Hose heat circuit breaker trips.  | 2                |
| Hose temperature not maintained during flow.                                      | 7, 8             |
| Hose or hoses adjacent to the unit are warm, hoses downstream are cold.           | 9                |

### Solutions

1. **Hose Length.** The hose heat system will maintain the temperature developed by the primary heaters with up to 410 ft (125 m) of hose. Longer hoses require an auxiliary hose heat system. If ambient temperature is too cold, the hose circuit may not have enough power to maintain the temperature.
2. **Hose Heat Primary Circuit Breaker.** Turn OFF the red main power disconnect and lock out incoming power at the source. Open the console and locate the hose heat circuit breaker. Reset the breaker if necessary. If the circuit breaker trips again, go to solutions 5 and c on page 16.

Do not reset the primary or secondary circuit breakers more than once. You must determine the cause of the problem and correct it.

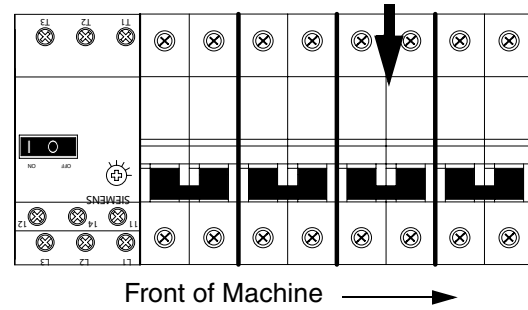

FIG. 6. Hose Heat Circuit Breaker

3. **Hose Heat Secondary Circuit Breaker.** Turn OFF the hose heater switch, control power switch, and the main power disconnect. Open the transformer compartment and locate the secondary hose heat circuit breaker on the left side. If necessary, reset the breaker by turning it off, and then turning it back on. If the circuit breaker trips again, go to solutions 5 and c on page 15.
4. **Hose Heat Temperature Controller.** The hose heat temperature controller (FIG. 7) is programmed for manual operation in the event of a thermocouple failure and is not interchangeable with the primary heater controllers. To test for a faulty controller, switch OFF and lockout incoming power at the source, and substitute another hose heat controller known to be good. If the controller alternately displays SbEr and H2000, see step c on page 16. For all other error codes, replace the controller.

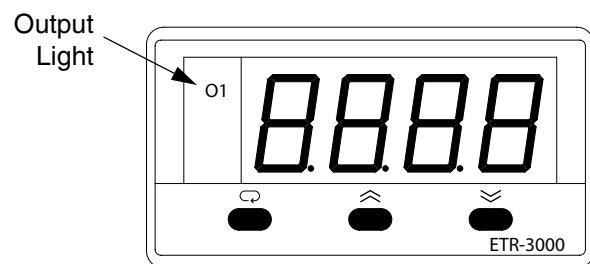
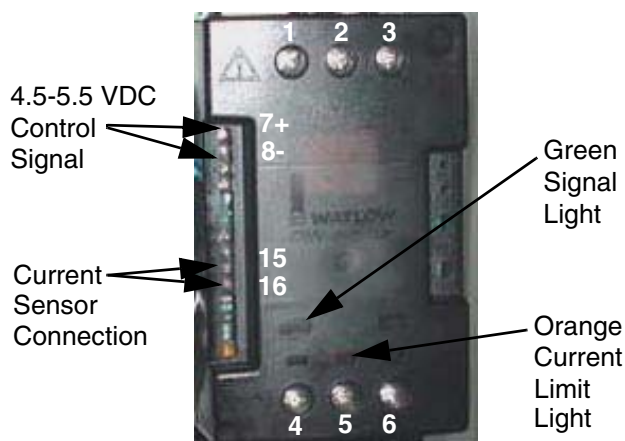

FIG. 7. Temperature Zone Controller

5. **Heated Hose Power Controller.** The controller, next to the hose transformer in the lower compartment, requires four conditions to be met for proper function:

- 210-240 Vac to power the controller, or 460 Vac on the 460 Vac units
- 4.5 to 5.5 Vdc to operate the control circuit
- a complete electrical circuit through the hose heaters, transformer secondary, and secondary circuit breaker
- transformer secondary current sensor connected

If these four conditions are met, one green and one orange status lights are illuminated. This only happens if the hose zone controller output light is on. If the zone controller light is flickering on less than 50%, the orange light may not be illuminated.



**FIG. 8: Heated Hose Power Controller**

a. **Problem:** Status lights are out, and hose zone controller output light is on.

**Cause:** Loss of ac or dc power.

**Solutions:**

- 1) Connect a voltmeter across terminals 2 and 3 on the power controller. If 210-240 Vac or 460 Vac is present, proceed to solution 2. If voltage is not present, turn off power to the machine. Open the console and locate the hose heat circuit breaker. Reset if necessary. Recheck to ensure that power is present between terminals 2 and 3.

- 2) Connect a voltmeter across terminals 7 and 8 on the power controller. If 4.5 to 5.5 Vdc is present with the positive on terminal 7, replace the power control unit. The dc voltage is supplied to the controller by the hose heat temperature controller. If 4.5 to 5.5 Vdc is not present, check the wiring from the temperature controller. If the wiring is correct, replace the hose heat temperature controller. (See Solution 4.)

b. **Problem:** Green signal light is illuminated, while the hose zone controller output light is illuminated, but the orange light never illuminates and the hose does not heat.

**Cause:** Open hose heat circuit or defective power control module, or there is no sensor signal.

**Solution:**

- 1) Check current sensor, wire, and connections to 15 and 16.
- 2) Disconnect the hose heat by unplugging the Power Lock connector at the machine. Turn on the hose heat. Connect a voltmeter across the terminals of the Power Lock connector on the machine. If 120 V is present, there is an open circuit in the hose heat circuit. If no voltage is present, replace the power control module.



6. **Temperature Sensing Unit (TSU).** An alternating display of SbEr and H2000 indicates a loss of signal from the TSU. Two conditions must be satisfied for proper TSU operation:





- The sensor must be functional.
- The signal must travel uninterrupted from the sensor to the control unit.

Unplug the TSU from its extension. Without disconnecting any hose sections, move hose section with TSU close to proportioning unit. Plug TSU into TSU extension harness, restore electrical power, and replace TSU. If control is restored, systematically check each section of TSU wire harness to gun.

**Manual Hose Heat Control.** In event of a TSU failure, controller automatically switches to manual mode, allowing temporary manual control of hose heat until TSU can be replaced. During manual mode, the “power on” time on the controller drops to

20% of normal cycle and must be adjusted up or down as required. To convert to manual control, proceed as follows:

- a. Turn OFF the hose heat switch and main power disconnect.
- b. Manual hose heat control requires installation of a hose thermometer. Insert hose thermometer through sponge in 10 ft. gun hose, so stem follows twist of hoses and lies between butyl inner hose and outer insulation. This gives the most accurate temperature indication. Choose a location where the thermometer is inserted easily through sponge without excessive force and close enough to the gun to be readable while spraying.
- c. Switch ON main disconnect and hose heater switch. When heater controller display reads H2000, press  or  button to increase or decrease the “power on” time percentage. Use only enough power to maintain fluid temperature after fluid leaves primary heaters.
- d. Proceed with operation and monitor thermometer for proper spray temperature.

|   |   |   |   |  |  |  |
|---|---|---|---|--|--|--|
|    |  |  |  |  |  |  |
| <p>Do not allow hose to overheat during manual control. Hose temperature, as indicated by a properly installed hose thermometer, must not exceed 170°F (76°C). Closely monitor hose temperature to avoid personal injury or damage to property.</p> |   |   |   |  |  |  |

7. **Primary Heat and Hose Heat Settings.** The purpose of the hose heat system is not to add heat but to maintain the temperature developed by the primary heater. If it appears that the hose heat system is not maintaining temperature during flow, ensure that primary heater and hose heat controllers are set for proper temperatures, or reduce output.
  - e. **Low Line Voltage.** The hose heat system operates from 220 Vac. Low line voltage will significantly reduce power available and the heater will not perform to its full capability at maximum hose length.

8. **Hose Heating Element.** With hose heater switch OFF, ensure that Power Lock connectors on hoses and all electrical connections between hoses and proportioning unit are tight. If these connections are secure and hose heat is not present, perform a systematic search for the electrical fault as follows:

- a. With hose heater switch OFF, starting at gun whip hose, unplug Power Lock connectors and plug the 15C517 hose jumper plug (provided) into last “upstream” segment of hose.
- b. Turn ON hose heater switch. If hose heat is restored, then the fault is within the gun whip hose.
 

If hose heat is not restored, turn OFF hose heater switch, control power switch, and main power disconnect, and proceed with the following steps.
- c. Unplug next set of Power Lock connectors and plug hose jumper plug into last “upstream” segment of hose.
- d. Restore power and turn ON hose heater switch. If hose heat is restored, then the fault is within the last unplugged segment of hose.

If hose heat is not restored, turn OFF hose heater switch, control power switch, and main power disconnect. Repeat steps c and d until the fault is located.

 **Repair Note:** When inserting contact into connector (D) ensure that notch of contact snaps over edge of spring clip as shown in the cutaway drawing below.

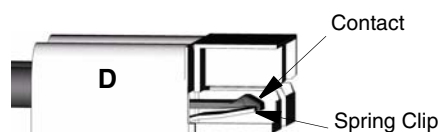
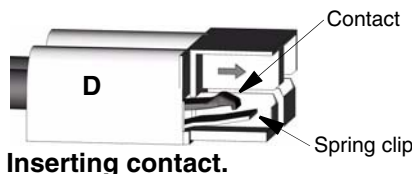



# Repair

## Primary Heaters

### Heater Cartridges



The sheath on the heater cartridges is made of an alloy which is resistant to corrosion and erosion. However, if the sheath should fail, fluid under pressure will leak into the heater cartridge. This may result in leakage through the junction end of the cartridge.

1. Turn OFF the main disconnect.
2. Remove the heater cover.
3. If removing the front outboard heater cartridge, the thermocouple must be removed. Using an open-end wrench, loosen the compression nut that holds the thermocouple in place. Remove the thermocouple.
4. Disconnect the heater cartridge lead wires and, using an open end wrench, loosen the heater cartridge and remove it. Since fluid surrounds each cartridge, be prepared to catch the residual fluid as the cartridge is withdrawn. Inspect the cartridge. It should be relatively smooth and shiny. If there is a crusted, burnt, ash-like material adhered to the cartridge or the sheath shows pitting marks, replace the cartridge.
5. Check the heater cartridge resistance. See page 9.
6. Apply thread sealant to the heater cartridge threads and install the cartridge, using an open-end wrench.
7. Install the thermocouple. See **Thermocouple Replacement**.
8. Reconnect the heater cartridge leadwires to the power leads, wiring them in parallel.
9. Replace the heater cover.

### Over-temperature Switch

1. Turn OFF the main disconnect.
2. Remove the heater cover.
3. Remove one connector to test continuity across terminals. Test leads should read 0 if cooler than 230°F. If test leads read open resistance, replace over-temperature switch.

### Thermocouple Replacement



The thermocouple includes the compression nut and ferrule. Once locked in place, the ferrule becomes a permanent part of the thermocouple and cannot be relocated or removed. The location of the thermocouple is critical to the operation of the primary heater and requires proper positioning before tightening the compression nut.

1. Relieve pressure, page 6.
2. Turn OFF the main disconnect.
3. Using an open end wrench, securely tighten the compression fitting body into the heat exchanger tube to prevent any leakage.
4. Install the heater cartridge and heat exchanger spring into the tube, if they were removed.

5. With the compression nut and ferrule in place, insert the thermocouple into the body until it makes contact with the heater cartridge. Make sure that the spring does not obstruct the placement of the thermocouple against the cartridge.
6. Firmly hold the thermocouple in place against the cartridge and, using an open end wrench, tighten the compression nut.

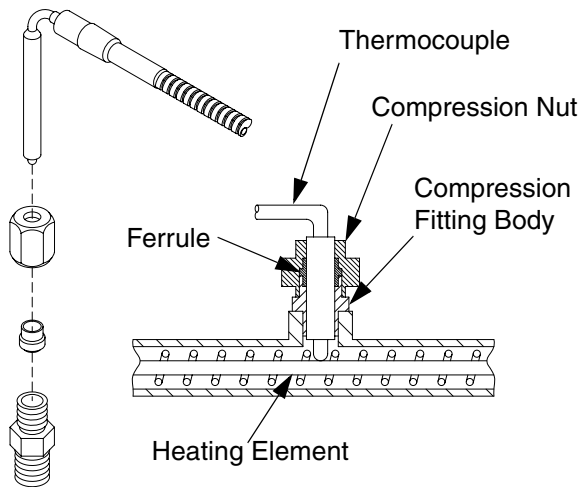



FIG. 9. Thermocouple Components

 Clean the A-side screen only during daily startup. This minimizes moisture contamination by immediately flushing out any isocyanate residue at the start of dispensing operations.

1. Close the material supply valve at the pump inlet and shut off the hydraulic supply to the appropriate proportioning pump. This prevents material from being pumped while the strainer screw is removed.
2. Place a container under the strainer base to catch drain off when removing the strainer screw.
3. Remove the screen from the strainer base. Thoroughly flush the screen with gun cleaner and shake it dry. Inspect the screen for blockage. No more than 25% of the mesh should be restricted. If more than 25% is blocked, replace the screen. Inspect the strainer screw gasket and replace as required.
4. Install the strainer screw with the spring, screen, and gasket in place and tighten. Take care to not overtighten. Let the gasket make the seal.
5. Open the material supply valve, ensure that there are no leaks, and wipe the equipment clean.
6. Proceed with operation.

## Proportioning Pumps

For proportioning pump repair instructions, including disassembly and assembly, see Proportioning Pumps manual 312068.

### Inlet Fluid Strainer Screen

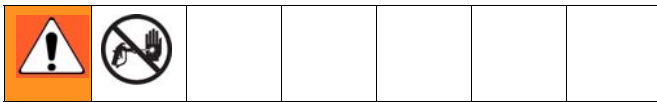

The inlet strainer at each proportioning pump filters out solid matter that can plug the inlet check valves. Inspect the screens daily as part of the startup routine, and clean as required.

Isocyanate can crystallize from moisture contamination or from freezing. If the chemicals used are clean and proper storage, transfer, and operating procedures are followed, there should be minimal contamination of the A-side screen.

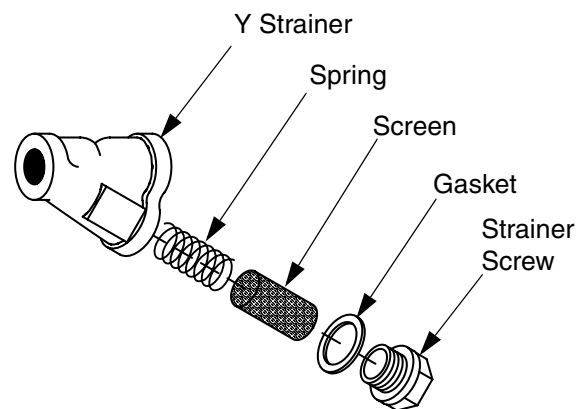

FIG. 10. Y Strainer Components

## Pump Lubrication System



Check the condition of the ISO pump lubricant daily. Change the lubricant if it becomes a gel, its color darkens, or it becomes diluted with isocyanate.

Gel formation is due to moisture absorption by the pump lubricant. The interval between changes depends on the environment in which the equipment is operating. The enclosed lubrication system minimizes exposure to moisture, but some contamination is still possible.

Discoloration of the lubricant is due to continual seepage of small amounts of isocyanate past the pump packings during operation. However, if the packings are operating properly, lubricant replacement due to discoloration should not be necessary more frequently than in 3 or 4 week intervals.

To change pump lubricant:

1. Relieve pressure, page 6.
2. Point the coupling block manual valves into a waste container and open them. Stop the ISO proportioning pump in the extreme right position by jogging the pump switch. Close the manual valves and turn off the hydraulic motor switch and pump switch.
3. Lift the lubricant reservoir out of the bracket and remove the container from the cap. Holding the cap over a suitable container, remove the check valve and allow the lubricant to drain. Reattach the check valve to the inlet hose.
4. Drain the reservoir and flush it with clean lubricant.
5. When the reservoir is flushed clean, fill with fresh lubricant.
6. Thread the reservoir onto the cap assembly and place it into the bracket. See FIG. 11.
7. Push the larger diameter supply tube approximately 1/3 of the way down into the reservoir.
8. Push the return tube down into the reservoir until it touches the bottom.
9. The lubrication system is ready for operation. No priming is required.

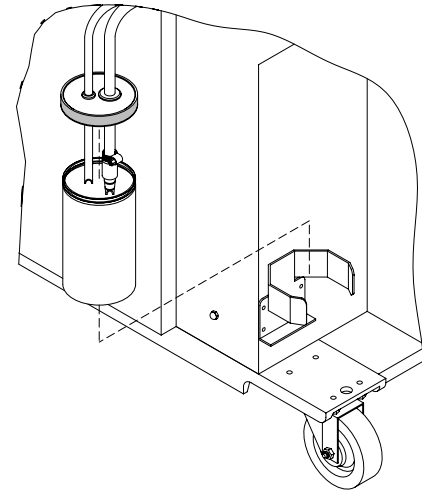

**FIG. 11. Pump Lubrication System**

## Hydraulic Drive System



Check the cleanliness of the fluid in the hydraulic drive system annually. Change the fluid in accordance with the fluid manufacturer's recommendations.

1. Relieve pressure, page 6.
2. Allow the hydraulic fluid to cool.
3. Thoroughly clean the tank top, access cover plate, and components in the area of the cover plate. This ensures that no foreign matter will enter the hydraulic reservoir when removing the cover plate.
4. Remove the six cover plate mounting screws. Separate the hydraulic suction pipe from the fitting connecting the pipe to the hydraulic pump.

5. Remove the cover and pipe from the hydraulic reservoir.
6. Inspect the bottom of the reservoir for sediment. If sediment is present, drain the hydraulic fluid, thoroughly clean the tank, and refill with new fluid.
7. Replace the cover and suction pipe, connect and tighten the suction pipe to the fitting on the hydraulic pump, and secure the cover with the mounting screws.
8. Check to ensure that the hydraulic pump is filled with hydraulic fluid.
9. Proceed with normal operation.



Upon starting the motor, the hydraulic pump may make a screeching noise. If this noise continues for more than 30 seconds, switch off the motor control. See **Troubleshooting, Hydraulic Drive System**, page 13.

# Parts

## Final Assembly

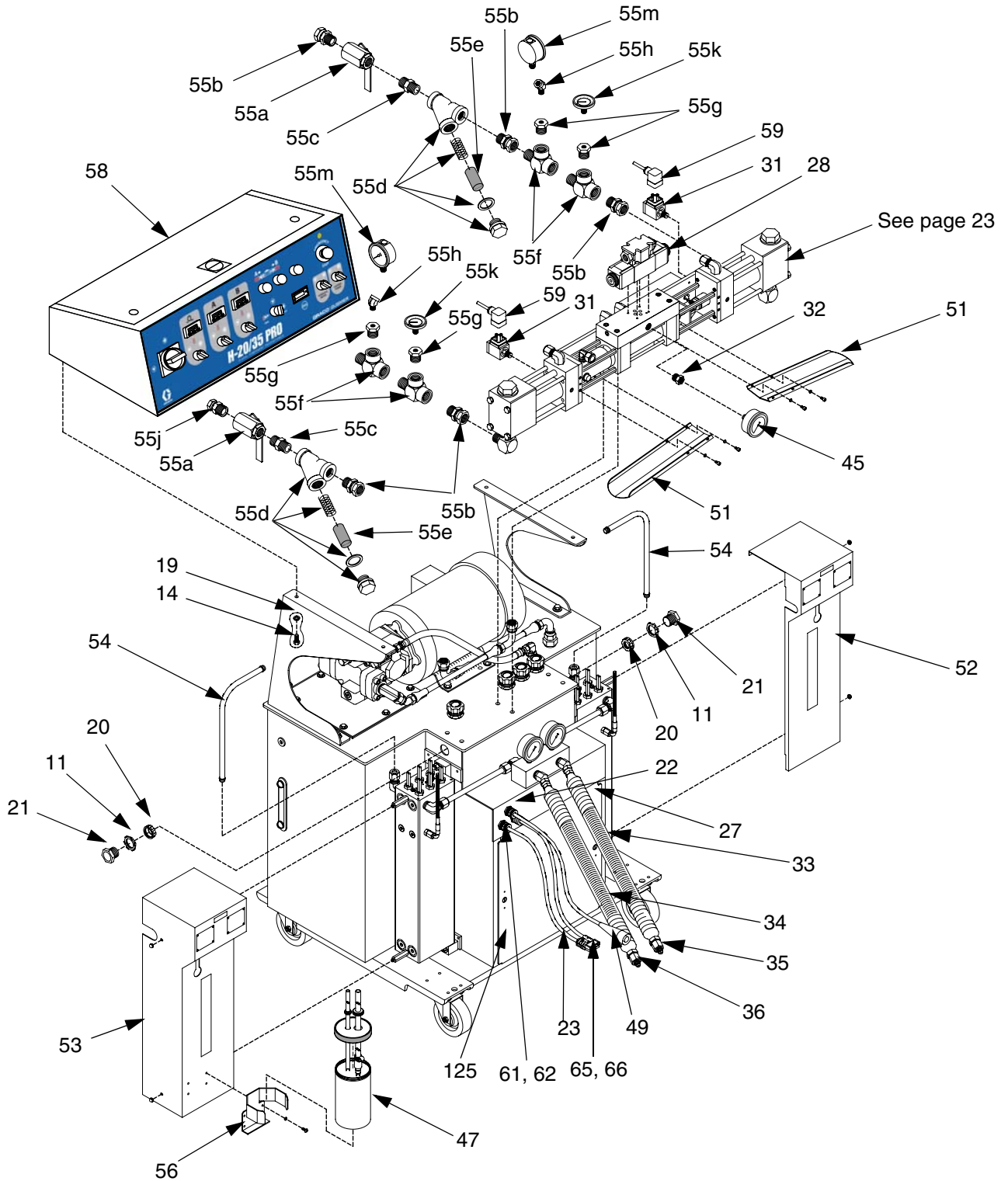

# Base Assembly

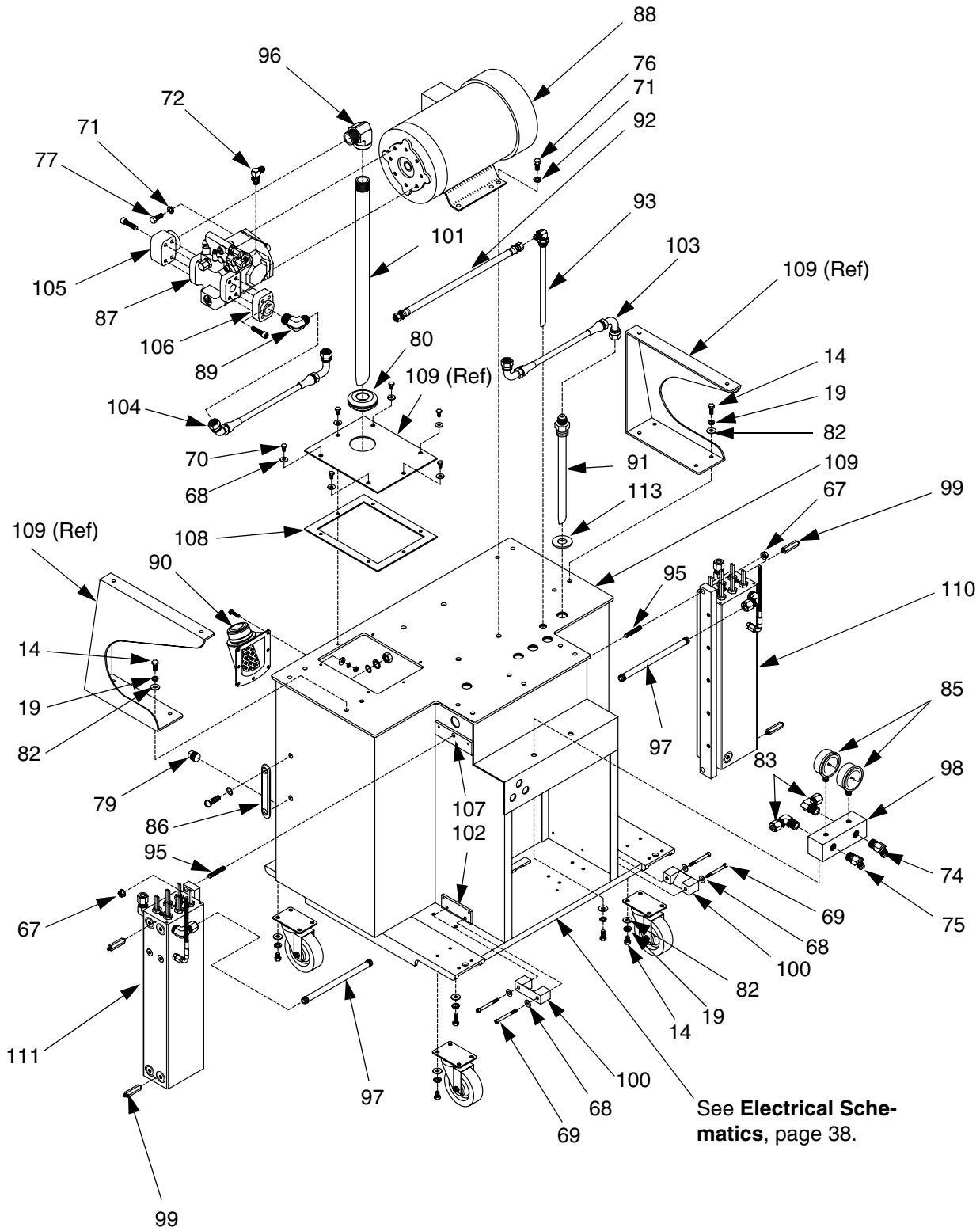

# Proportioner Assembly

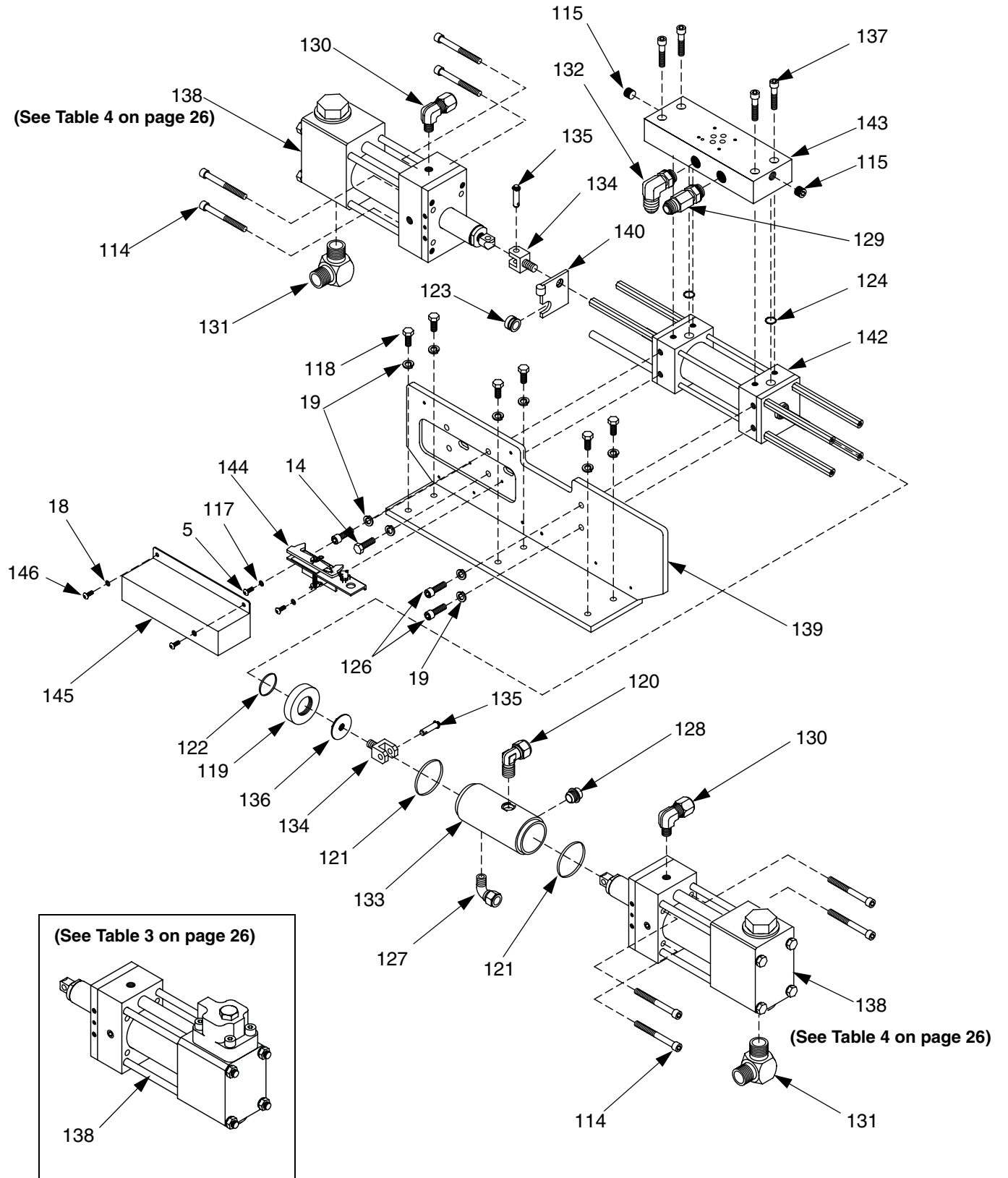

Parts

| Ref. | Part   | Description  | Qty. | Ref. | Part   | Description   | Qty. |
|------|--------|--|------|------|--------|---|------|
| 5    |        | SCREW, machine; 8-32 x 3/8 in. (10 mm)                                   | 4    | 69   | 101950 | SCREW, cap, socket hd; 1/4-20 x 2-1/2 in. (64 mm)                               | 4    |
| 11   | 295736 | NUT, lock  | 2    | 70   | C19080 | SCREW, cap, hex hd; 1/4-20 x 1/2 in. (13 mm)                                    | 6    |
| 13   | 295737 | NUT, wire  | 6    | 71   | 100133 | WASHER, lock, spring; 3/8   | 6    |
| 14   |        | SCREW, cap, hex hd; 5/16-18 x 3/4 in. (19 mm)                            | 15   | 72   | 295770 | ELBOW, with o-ring; 9/16-18   | 1    |
| 19   |        | WASHER, lock, spring; 5/16   | 25   | 74   | 117557 | ELBOW, 45°; #10 JIC x 1/2 npt   | 1    |
| 20   | 295739 | BUSHING, conductive; 3/4   | 2    | 75   | 117556 | ELBOW, 45°; #8 JIC x 1/2 npt  | 1    |
| 21   | 295740 | NIPPLE; 3/4  | 2    | 76   | 100469 | SCREW, cap, hex hd; 3/8-16 x 3/4 in. (19 mm)                                    | 4    |
| 22   | 295741 | STRAIN RELIEF  | 1    | 77   | 100101 | SCREW, cap, hex hd; 3/8-16 x 1 in. (25 mm)                                      | 2    |
| 27▲  | 295452 | LABEL, warning, high voltage   | 1    | 79   | 100737 | PLUG, drain; 1/2 npt  | 1    |
| 28   | 295747 | VALVE, directional   | 1    | 80   | 295773 | GROMMET; rubber; 1-1/4 in. (32 mm) ID   | 1    |
| 31   | 296821 | SWITCH, pressure; 2200 psi (15.2 MPa, 152 bar); Model H20 Pro            | 2    | 82   |        | WASHER, flat; 5/16  | 10   |
|      | 296822 | SWITCH, pressure; 2800 psi (19.3 MPa, 193 bar); Model H25 Pro            | 2    | 83   | 117532 | ELBOW; 1/2 npt(m) x 1/2 (13 mm) OD tube   | 2    |
|      | 296817 | SWITCH, pressure; 3700 psi (25.5 MPa, 255 bar); Model H35 Pro            | 2    | 85   | 102814 | GAUGE, pressure, fluid; 0-5000 psi (34.5 MPa, 345 bar)                          | 2    |
| 32   | 100206 | BUSHING; 1/2 npt(m) x 1/4 npt(f)   | 1    | 86   | 295777 | GAUGE, fluid level  | 1    |
| 33   | 296412 | HOSE, isolation, R, 1/2 in. x 2 ft.                                      | 1    | 87   | 295778 | PUMP, hydraulic, bare   | 1    |
| 34   | 296413 | HOSE, isolation, A, 1/2 in. x 2 ft.                                      | 1    | 88   | 296781 | MOTOR, electric, 1 phase; used on Part Nos. 295500, 295507, 295514, 295515 only | 1    |
| 35   | 117677 | FITTING, reducer, 6 x 10 JIC   | 1    |      | 296780 | MOTOR, electric, 3 phase; used on all other part nos.                           | 1    |
| 36   | 117502 | FITTING, reducer, 5 x 8 JIC  | 1    | 89   | 295780 | ELBOW; 3/4 npt(m) x 7/8-14 JIC  | 1    |
| 41▲  | 295753 | LABEL, warning, high voltage   | 1    | 90   | 295781 | FILLER, hydraulic oil   | 1    |
| 45   | 296729 | GAUGE, pressure, hydraulic; 0-2000 psi (13.8 MPa, 138 bar)               | 1    | 91   | 295782 | RETURN, hydraulic reservoir; 7/8-14 JIC   | 1    |
| 47   | 296731 | KIT, reservoir, lubrication  | 1    | 92   | 295783 | HOSE, bleed   | 1    |
| 49   | 295480 | WIRE ASSY, temperature sensing unit                                      | 1    | 93   | 295784 | RETURN, hydraulic reservoir; 1/2 in. (13 mm) tube                               | 1    |
| 51   | 295759 | DRIP PAN   | 2    | 94   |        | RIVET, pop; 3/8-16 x 1/2 in. (13 mm)  | 8    |
| 52   | 296247 | COVER, heater, B-side  | 1    | 95   | 295785 | ROD, threaded; 3/8-16 x 2 in. (51 mm)   | 2    |
| 53   | 295761 | COVER, heater, A-side  | 1    | 96   | 110300 | ELBOW; 1 in. npt(m) x 1 in. npt(f)  | 1    |
| 54   | 295762 | TUBE, pump/heater  | 2    | 97   | 295787 | TUBE, manifold outlet   | 2    |
| 55   | 296175 | KIT, inlet; includes items 55a-55m; kit supplies parts for A and B-sides | 1    | 98   | 295788 | MANIFOLD  | 1    |
| 55a  | 109077 | . VALVE, ball; 3/4 npt (fbe)   | 2    | 99   | 295789 | STANDOFF, cover, preheater  | 4    |
| 55b  | 157785 | . UNION, swivel; 3/4 npt(m) x 3/4 npsm(f)                                | 5    | 100  | 295790 | BLOCK, mounting, preheater  | 2    |
| 55c  | C20487 | . NIPPLE; 3/4 npt  | 2    | 101  | 295791 | TUBE, suction; 1 in. npt x 24 in. (610 mm)                                      | 1    |
| 55d  | 101078 | . Y-STRAINER; includes 55e   | 2    | 102  | 295792 | PAD, thermal, heater  | 2    |
| 55e  | 180199 | . . ELEMENT, 20 mesh   | 1    | 103  | 295793 | HOSE, T-port  | 1    |
| 55f  | 111337 | . TEE, street; 3/4 npt (m x f x f)                                       | 4    | 104  | 295795 | HOSE, P-port  | 1    |
| 55g  | 100615 | . BUSHING; 3/4 npt(m) x 1/4 npt(f)                                       | 4    | 105  | 295818 | FLANGE, suction; 1 in. npt  | 1    |
| 55h  | 110733 | . ELBOW, 45°; 1/4 npt (m x f)  | 2    | 106  | 295819 | FLANGE, outlet; 3/4 npt   | 1    |
| 55j  | 296827 | . UNION, swivel, A-side; 3/4 npt(m) x 1/2 npt(f)                         | 1    | 107  | 295820 | PAD, thermal, heater  | 2    |
| 55k  | 102124 | . DIAL, temperature, fluid   | 2    | 108  | 295821 | GASKET, plate, access cover   | 1    |
| 55m  | 296220 | . GAUGE, pressure, fluid   | 2    | 109  | 295005 | TANK, hydraulic   | 1    |
| 56   | 295763 | BRACKET, reservoir   | 1    |      |        |   |      |
| 58   |        | CONSOLE; see page 35   | 1    |      |        |   |      |
| 59   | 295216 | CONNECTOR, DIN, psi switch   | 1    |      |        |   |      |
| 61   | 295268 | BUSHING  | 2    |      |        |   |      |
| 62   | 295269 | NUT, lock  | 2    |      |        |   |      |
| 65   | 117789 | HOUSING, connector, wire   | 1    |      |        |   |      |
| 66   | 295767 | CONTACT, connector, wire; #6   | 2    |      |        |   |      |
| 67   | 295768 | NUT, flange; 3/8-16  | 2    |      |        |   |      |
| 68   | 502682 | WASHER, flat; 1/4  | 10   |      |        |   |      |



| Ref. | Part    | Description  | Qty. | Ref. | Part    | Description  | Qty. |
|------|---------|--|------|------|---------|--|------|
| 110  | 295628  | HEATER, basic, B-side; 1000 W; used on Part Nos. 295505, 295512, 295522; see page 27   | 1    | 130  | 120401  | ELBOW; 3/4-15 unf x 1/2 in. (13 mm) OD tube        | 2    |
|      | 295629  | HEATER, basic, B-side; 1000 W; used on Part Nos. 295500, 295501, 295503, 295507, 295508, 295510, 295514, 295515, 295516, 295517, 295520; see page 27 | 1    |      | ★295830 | ELBOW; 1/4 npt(m) x 1/2 in. (13 mm) OD tube        | 2    |
|      | 295630  | HEATER, basic, B-side; 1500 W; used on Part Nos. 295502, 295504, 295509, 295511, 295518, 295519, 295521; see page 27                                 | 1    | 131  | 296648  | ELBOW, street; 3/4 npt (mbe)                       | 2    |
|      | 295631  | HEATER, basic, B-side; 1500 W; used on Part Nos. 295506, 295513, 295523; see page 27   | 1    | 132  | 295848  | ELBOW; 3/4-16 ORG x 7/8-14 JIC                     | 1    |
| 111  | 295632  | HEATER, basic, A-side; 1000 W; used on Part Nos. 295505, 295512, 295522; see page 28   | 1    | 133  | 298107  | CYLINDER, lube, ISO                                | 1    |
|      | 295633  | HEATER, basic, A-side; 1000 W; used on Part Nos. 295500, 295501, 295503, 295507, 295508, 295510, 295514, 295515, 295516, 295517, 295520; see page 28 | 1    |      | ★296651 | CYLINDER, lube, ISO                                | 1    |
|      | 295634  | HEATER, basic, A-side; 1500 W; used on Part Nos. 295502, 295504, 295509, 295511, 295518, 295519, 295521; see page 28                                 | 1    | 134  | 296652  | CLEVIS, hydraulic cylinder                         | 1    |
|      | 295635  | HEATER, basic, A-side; 1500 W; used on Part Nos. 295506, 295513, 295523; see page 28   | 1    | 135  | 296653  | PIN, clevis  | 2    |
| 112▲ | 295822  | LABEL, warning, hot surface  | 2    | 136  | 295852  | NUT, jam   | 1    |
| 113  | 295823  | WASHER, flat; 1 in. size   | 1    | 137  |         | SCREW, cap, socket hd; 5/16-18 x 1-1/2 in. (38 mm) | 1    |
| 114  |         | SCREW, cap, socket hd; 5/16-24 x 3 in. (76 mm)   | 8    | 138  |         | PUMP, proportioning, see tables on page 26.        | 2    |
| 115  |         | PLUG, pipe, flush seal; 1/4 npt  | 2    | 139  | 295854  | L-BRACKET, mounting, pump                          | 1    |
| 116  | 296783  | KIT, accessory   | 1    | 140  | 295855  | PLATE, activator                                   | 1    |
| 117  |         | WASHER, lock, internal tooth; #8   | 2    | 142  | 295027  | CYLINDER, hydraulic, w/spacers; see page 29        | 1    |
| 118  |         | SCREW, cap, hex hd; 5/16-24 x 1 in. (25 mm)  | 6    | 143  | 298040  | MANIFOLD, hydraulic                                | 1    |
| 119  | 298111  | PLATE, adapter, lube cylinder  | 1    | 144  | 295571  | SWITCH, reversing; see page 29                     | 1    |
|      | ★295825 | PLATE, adapter, lube cylinder  | 1    | 145  | 295858  | COVER, switch, reversing                           | 1    |
| 120  | 295826  | ELBOW; 1/4 npt(m) x 3/8 in. (10 mm) OD tube  | 1    | 146  |         | SCREW, cap, button hd; 10-32 x 1/4 in. (6 mm)      | 2    |
| 121  | 106258  | O-RING   | 2    | 148  | 296810  | KIT, tool; includes items 148a-148f; not shown     | 1    |
|      | ★295827 | O-RING   | 2    | 148a | 296605  | . MAGNET PEN                                       | 1    |
| 122  | 177156  | O-RING; fluoroelastomer  | 1    | 148b | 296606  | . TOOL, 1/4 hex ball drive                         | 1    |
| 123  | 295828  | BUSHING; bronze  | 1    | 148c | 296607  | . EXTRACTOR, clevis pin                            | 1    |
| 124  | 112793  | O-RING; buna-N   | 2    | 148d | 296608  | . TOOL, ball seat removal, large                   | 1    |
| 125  | 296357  | LABEL  | 1    | 148e | 296609  | . TOOL, ball seat removal, small                   | 1    |
| 126  |         | SCREW, cap, socket hd; 5/16-18 x 7/8 in. (22 mm)   | 3    | 148f | 296610  | . TOOL, control bulb removal                       | 1    |
| 127  | 295397  | ELBOW; 3/8 npt(m) x 1/2 in. (13 mm) OD tube  | 1    |      |         |  |      |
| 128  | 295829  | PLUG; 3/8 npt(m); plastic  | 1    |      |         |  |      |
| 129  | 296223  | FITTING, straight  | 1    |      |         |  |      |

▲ Replacement Danger and Warning labels, tags, and cards are available at no cost.

★ For use with pumps in Table 3 on page 26.

† For use with pumps in Table 4 on page 26.

**Table 3. Obsolete Proportioning Pumps**

| Part, Series | Cylinder Size | A-Side or B-Side |
|--------------|---------------|------------------|
| 296757, A    | #30           | A-Side           |
| 295043, B    | #30           | B-Side           |
| 295044, B    | #40           | B-Side           |
| 295045, B    | #48           | B-Side           |
| 297675, B    | #60           | A-Side           |
| 296799, B    | #60           | B-Side           |
| 296807, B    | #80           | A-Side           |
| 296800, B    | #80           | B-Side           |
| 296750, A    | #88           | A-Side           |
| 296801, A    | #88           | B-Side           |
| 295155, A    | #96           | A-Side           |
| 296802, A    | #96           | B-Side           |
| 295156, B    | #104          | A-Side           |
| 295050, B    | #104          | B-Side           |
| 296806, A    | #112          | A-Side           |
| 295051, A    | #112          | B-Side           |
| 296749, B    | #120          | A-Side           |
| 296748, A    | #120          | B-Side           |

See manual 311391 for repair procedures and replacement parts.

**Table 4. Proportioning Pumps**

| Part, Series | Cylinder Size |
|--------------|---------------|
| 247371, A    | #30           |
| 247372, A    | #40           |
| 247373, A    | #48           |
| 247374, A    | #60           |
| 247375, A    | #80           |
| 255773, A    | #80           |
| 247577, A    | #88           |
| 247376, A    | #96           |
| 247377, A    | #120          |
| 247576, A    | #140          |

See manual 312068 for repair procedures and replacement parts.



If replacing pumps in *Table 3* with pumps in *Table 4*, it is recommended to replace both A and B sides and required to replace items 119, 121, 130, and 133.

Pumps in *Table 4* can be used on A-side or B-side.

**B-side Heater**

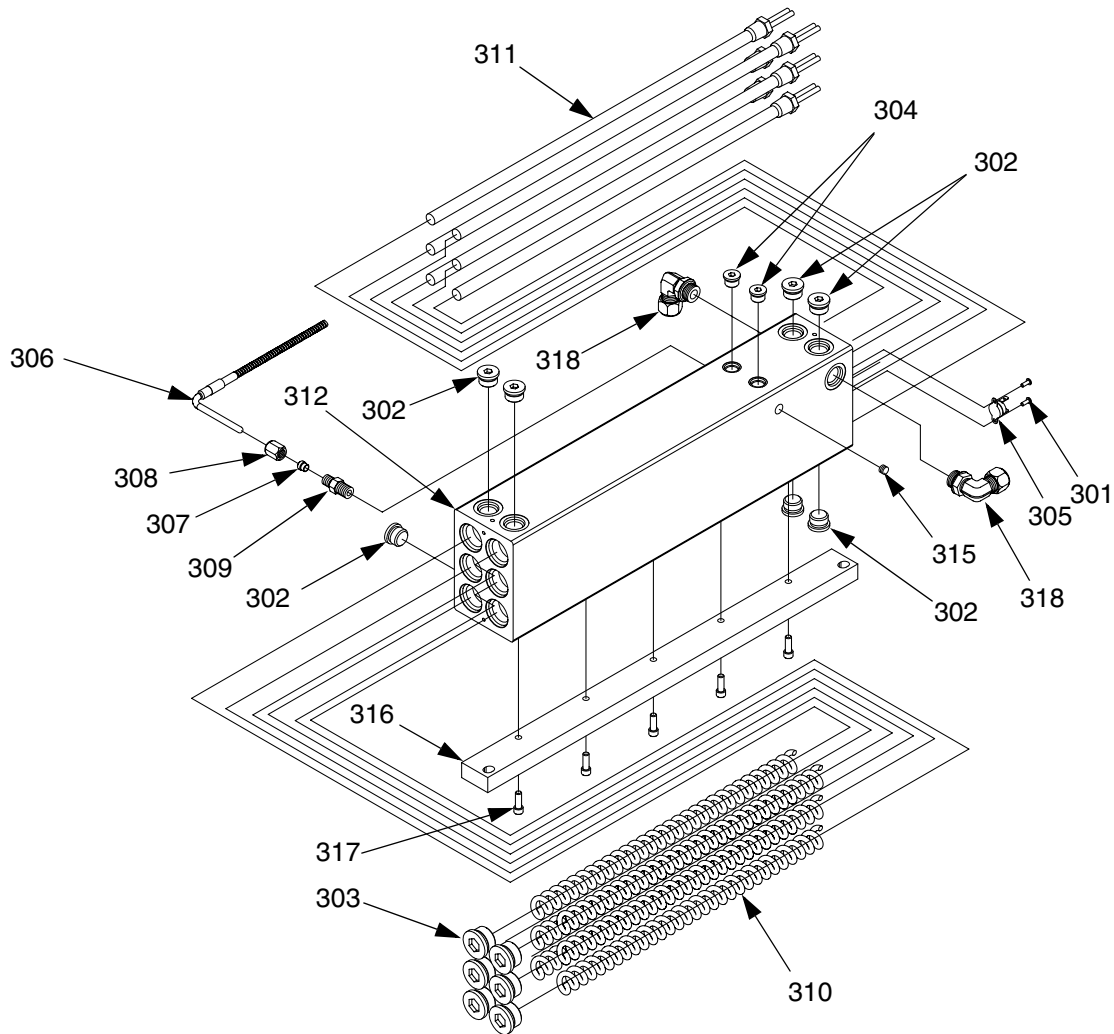

| Ref. | Part   | Description                                      | Qty. | Ref. | Part   | Description  | Qty. |
|------|--------|--|------|------|--------|--|------|
| 301  | 108026 | SCREW, cap, hex, button hd                       | 2    | 313  | 295196 | WASHER, lock, internal tooth; #10; not shown       | 1    |
| 302  | 295607 | PLUG, hex  | 7    | 314  | 195195 | SCREW, machine; 10-32 x 3/8 in. (10 mm); not shown | 1    |
| 303  | 295606 | PLUG, hex; 1-1/16                                | 6    | 315  | 100721 | PLUG, pipe, flush                                  | 1    |
| 304  | 108984 | PLUG, hex, hollow                                | 2    | 316  | 295608 | BASE, heater                                       | 1    |
| 305  | 295477 | SWITCH, over temperature                         | 1    | 317  | 112166 | SCREW, cap, socket hd                              | 5    |
| 306  | 296826 | THERMOCOUPLE                                     | 1    | 318  | 295603 | ELBOW  | 2    |
| 307  | 295605 | FERRULE, tube; 1/4 in. (6 mm)                    | 1    |      |        |  |      |
| 308  | 295604 | NUT, tube; 1/4                                   | 1    |      |        |  |      |
| 309  | 295611 | BODY, tube; 1/4 in. (6 mm)                       | 1    |      |        |  |      |
| 310  | 295610 | SPRING   | 6    |      |        |  |      |
| 311  | 295464 | CARTRIDGE, heater; 1000 W; used on 295629 Heater | 6    |      |        |  |      |
|      | 295465 | CARTRIDGE, heater; 1000 W; used on 295628 Heater | 6    |      |        |  |      |
|      | 296798 | CARTRIDGE, heater; 1500 W; used on 295630 Heater | 6    |      |        |  |      |
|      | 295467 | CARTRIDGE, heater; 1500 W; used on 295631 Heater | 6    |      |        |  |      |
| 312  | 295609 | SHEATH, heater                                   | 1    |      |        |  |      |

## A-Side Heater

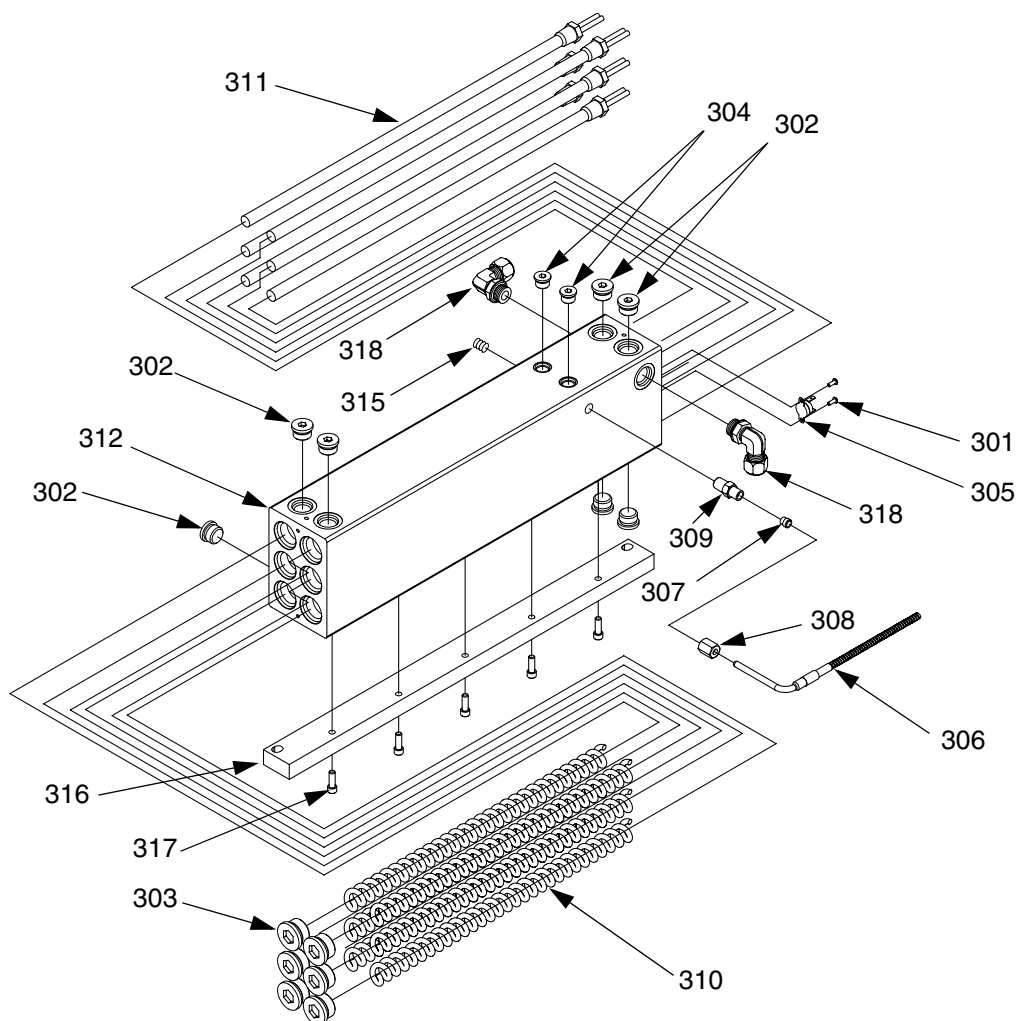

| Ref. | Part   | Description                                      | Qty. | Ref. | Part   | Description  | Qty. |
|------|--------|--|------|------|--------|--|------|
| 301  | 108026 | SCREW, cap, hex, button hd                       | 2    | 313  | 295196 | WASHER, lock, internal tooth; #10; not shown       | 1    |
| 302  | 295607 | PLUG, hex  | 7    | 314  | 295195 | SCREW, machine; 10-32 x 3/8 in. (10 mm); not shown | 1    |
| 303  | 295606 | PLUG, hex  | 6    | 315  | 100721 | PLUG, pipe, flush                                  | 1    |
| 304  | 108984 | PLUG, hex, hollow                                | 2    | 316  | 295608 | BASE, heater                                       | 1    |
| 305  | 295477 | SWITCH, over temperature                         | 1    | 317  | 112166 | SCREW, cap, socket hd                              | 5    |
| 306  | 296826 | THERMOCOUPLE                                     | 1    | 318  | 295603 | ELBOW  | 2    |
| 307  | 295605 | FERRULE, tube; 1/4 in. (6 mm)                    | 1    |      |        |  |      |
| 308  | 295604 | NUT, tube; 1/4                                   | 1    |      |        |  |      |
| 309  | 295611 | BODY, tube; 1/4 in. (6 mm)                       | 1    |      |        |  |      |
| 310  | 295610 | SPRING   | 6    |      |        |  |      |
| 311  | 295464 | CARTRIDGE, heater; 1000 W; used on 295633 Heater | 6    |      |        |  |      |
|      | 295465 | CARTRIDGE, heater; 1000 W; used on 295632 Heater | 6    |      |        |  |      |
|      | 295466 | CARTRIDGE, heater; 1500 W; used on 295634 Heater | 6    |      |        |  |      |
|      | 295467 | CARTRIDGE, heater; 1500 W; used on 295635 Heater | 6    |      |        |  |      |
| 312  | 295609 | SHEATH, heater                                   | 1    |      |        |  |      |

### 295027 Hydraulic Cylinder

**296786 Rod Bearings and Seals Kit**

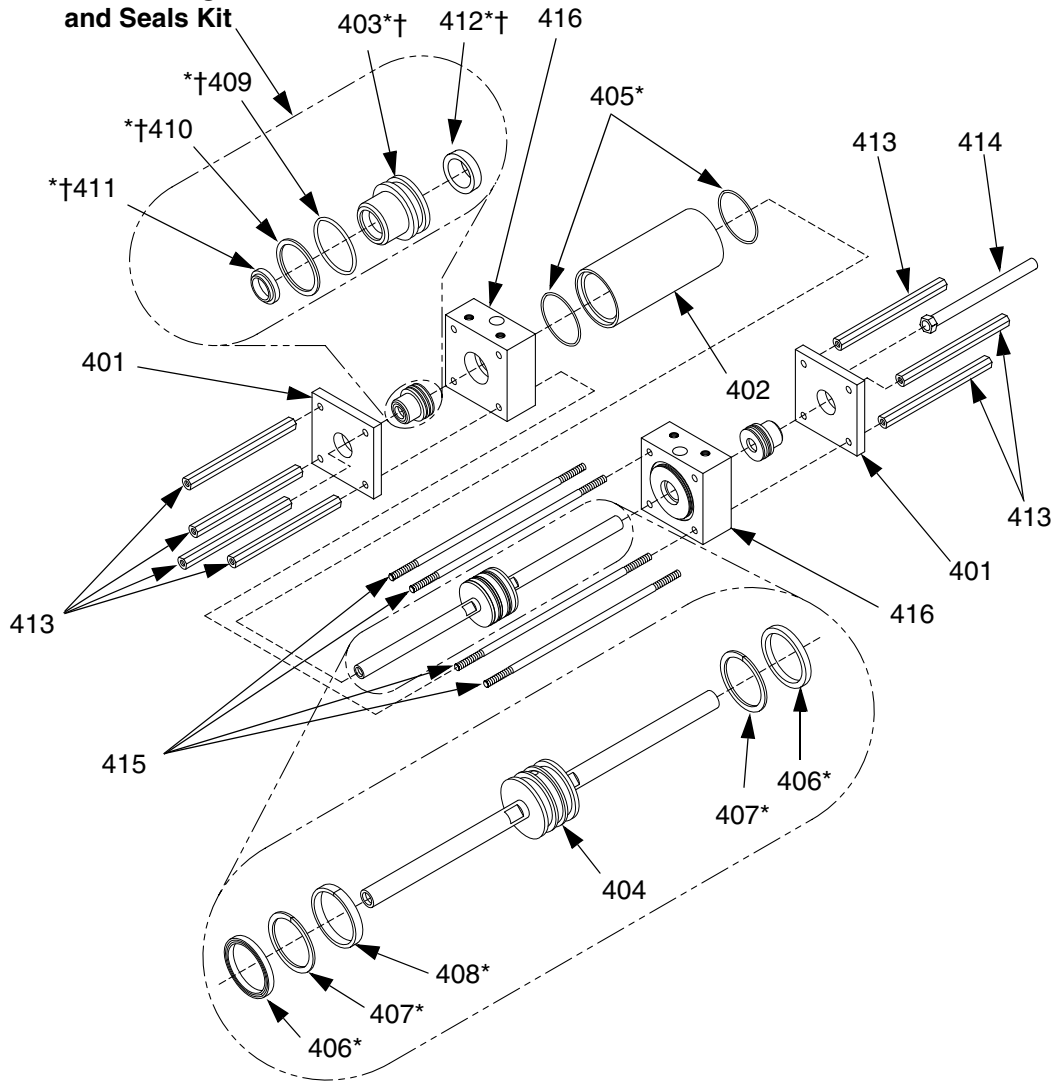

| Ref.  | Part   | Description     | Qty. | Ref.  | Part   | Description                  | Qty. |
|-------|--------|-----------------|------|-------|--------|------------------------------|------|
| 401   | 295029 | PLATE, retainer | 2    | 409*† |        | O-RING                       | 2    |
| 402   | 295030 | CYLINDER        | 1    | 410*† |        | RING, backup                 | 2    |
| 403*† | 295031 | BUSHING, rod    | 2    | 411*† |        | WIPER, rod                   | 2    |
| 404   | 296642 | PISTON          | 1    | 412*† |        | SEAL, shaft                  | 2    |
| 405*  |        | O-RING          | 2    | 413   | 295032 | SPACER, proportioner pump    | 7    |
| 406*  |        | U-CUP           | 2    | 414   | 295033 | SPACER, reverse switch pump  | 1    |
| 407*  |        | RING, backup    | 2    | 415   | 295034 | ROD, tie, hydraulic cylinder | 4    |
| 408*  |        | RING, wear      | 1    | 416   | 295035 | BLOCK, port                  | 2    |

\* Included in 296785 Cylinder Rebuild Kit.

† Included in 296786 Rod Bearings and Seals Kit.

### 296808 Reversing Switch Assembly

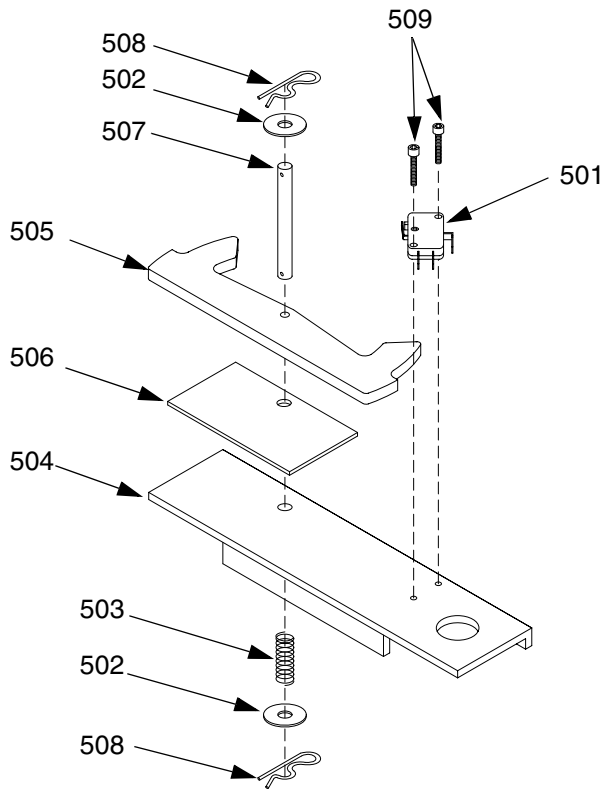

| Ref. | Part | Description           | Qty. |
|------|------|-----------------------|------|
| 501  |      | SWITCH                | 1    |
| 502  |      | WASHER, flat          | 2    |
| 503  |      | SPRING                | 1    |
| 504  |      | BRACKET, switch       | 1    |
| 505  |      | ARM, rocker           | 1    |
| 506  |      | PAD, arm, rocker      | 1    |
| 507  |      | PIN, arm, rocker      | 1    |
| 508  |      | CLIP, pin, hitch      | 2    |
| 509  |      | SCREW, cap, socket hd | 2    |



A series of horizontal lines for writing, consisting of 25 evenly spaced lines that span the width of the page.

## Lower Control Box Components

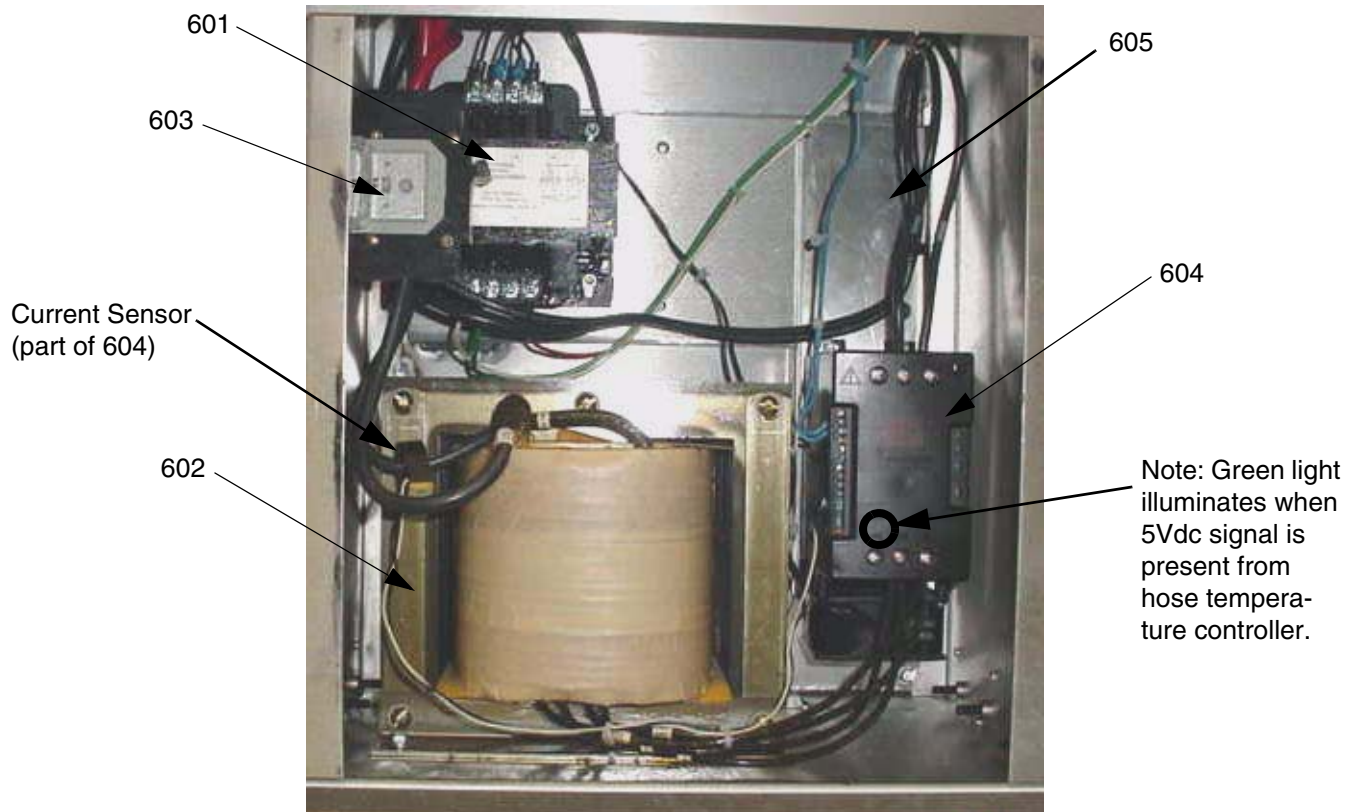

| Ref. | Part   | Description                           | Qty. |
|------|--------|---------------------------------------|------|
| 601  | 295748 | TRANSFORMER; 480/240-120V;<br>500 V/A | 1    |
| 602  | 295749 | TRANSFORMER; 5 kV/A                   | 1    |
| 603  | 295469 | BREAKER, circuit; 60 A; 2 pole        | 1    |
| 604  |        | CONTROL, hose heater, power           |      |
|      | 120387 | for all models except 460V model      | 1    |
|      | 120404 | for 460V model                        | 1    |
| 605  | 15H611 | BRACKET, mounting, heat<br>controller | 1    |



### Console

Also see 230V, 1 Phase Models 295500, 295507, 295514, 295515 (6 kW Heaters), pages 35-59.

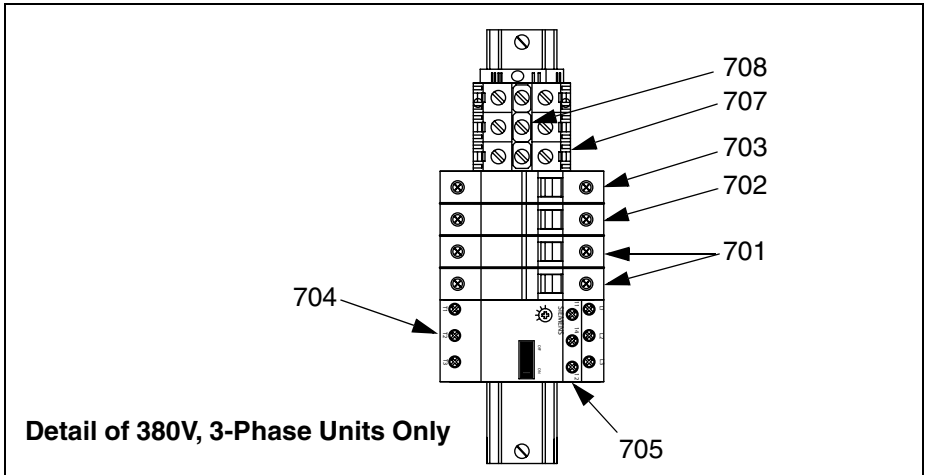
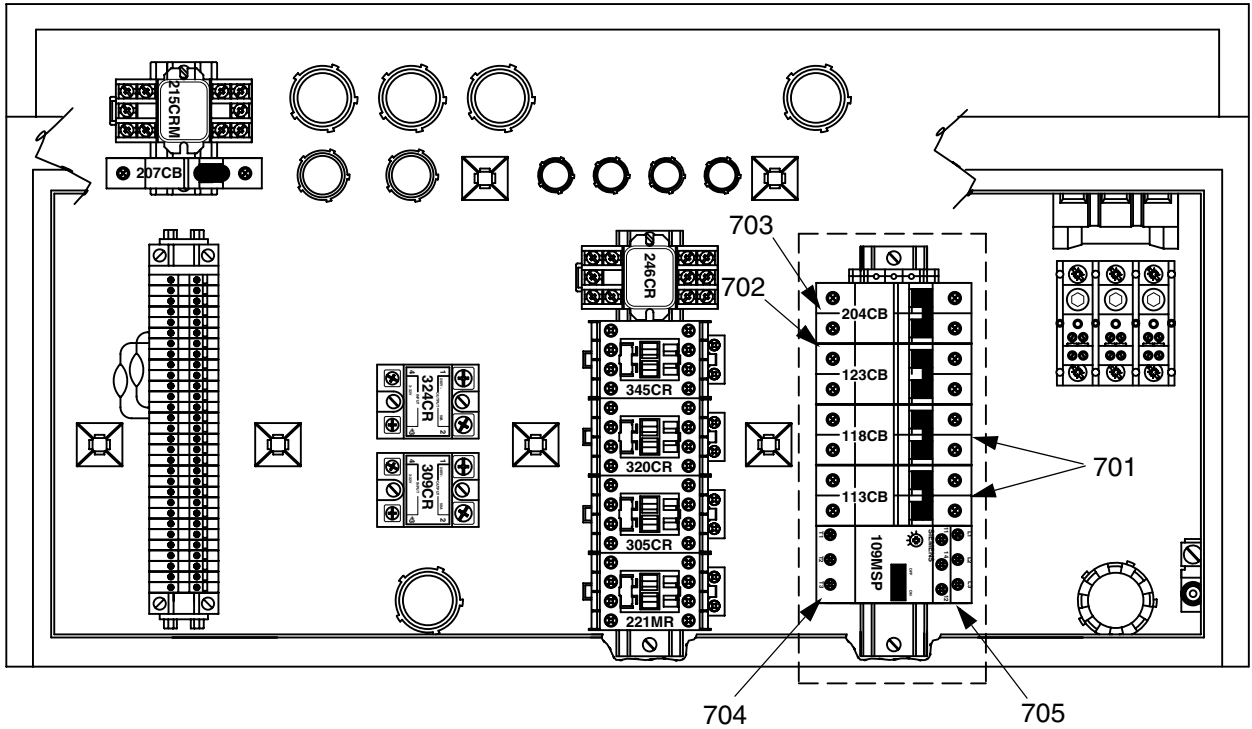

**230V, 1 Phase Models 295500, 295507, 295514, 295515 (6 kW Heaters)**

| Ref. | Part   | Description              | Qty. |
|------|--------|--------------------------|------|
| 701  | 295355 | CIRCUIT BREAKER, 32 A    | 2    |
| 702  | 295355 | CIRCUIT BREAKER, 32 A    | 1    |
| 703  | 295358 | CIRCUIT BREAKER, 8 A     | 1    |
| 704  | 295370 | PROTECTOR, motor start   | 1    |
| 705  | 295275 | CONTACT, auxiliary; SPDT | 1    |

**230V, 3 Phase Models 295501, 295508, 295516 (6 kW Heaters)**

| Ref. | Part   | Description              | Qty. |
|------|--------|--------------------------|------|
| 701  | 295355 | CIRCUIT BREAKER, 32 A    | 2    |
| 702  | 295355 | CIRCUIT BREAKER, 32 A    | 1    |
| 703  | 295358 | CIRCUIT BREAKER, 8 A     | 1    |
| 704  | 295369 | PROTECTOR, motor start   | 1    |
| 705  | 295275 | CONTACT, auxiliary; SPDT | 1    |

**230V, 3 Phase Models 295502, 295509, 295518, 295519 (9 kW Heaters)**

| Ref. | Part   | Description              | Qty. |
|------|--------|--------------------------|------|
| 701  | 295354 | CIRCUIT BREAKER, 50 A    | 2    |
| 702  | 295355 | CIRCUIT BREAKER, 32 A    | 1    |
| 703  | 295358 | CIRCUIT BREAKER, 8 A     | 1    |
| 704  | 295369 | PROTECTOR, motor start   | 1    |
| 705  | 295275 | CONTACT, auxiliary; SPDT | 1    |

**380V, 3 Phase Models 295503, 295510, 295517, 295520 (6 kW Heaters)**

| Ref. | Part   | Description              | Qty. |
|------|--------|--------------------------|------|
| 701  | 295353 | CIRCUIT BREAKER, 32 A    | 2    |
| 702  | 295353 | CIRCUIT BREAKER, 32 A    | 1    |
| 703  | 295357 | CIRCUIT BREAKER, 8 A     | 1    |
| 704  | 295368 | PROTECTOR, motor start   | 1    |
| 705  | 295275 | CONTACT, auxiliary; SPDT | 1    |

**380V, 3 Phase Models 295504, 295511, 295521 (9 kW Heaters)**

| Ref. | Part   | Description              | Qty. |
|------|--------|--------------------------|------|
| 701  | 120715 | CIRCUIT BREAKER, 50 A    | 2    |
| 702  | 295353 | CIRCUIT BREAKER, 32 A    | 1    |
| 703  | 295357 | CIRCUIT BREAKER, 8 A     | 1    |
| 704  | 295368 | PROTECTOR, motor start   | 1    |
| 705  | 295275 | CONTACT, auxiliary; SPDT | 1    |

**460V, 3 Phase Models 295505, 295512, 295522 (6 kW Heaters)**

| Ref. | Part   | Description              | Qty. |
|------|--------|--------------------------|------|
| 701  | 295351 | CIRCUIT BREAKER, 16 A    | 2    |
| 702  | 295351 | CIRCUIT BREAKER, 16 A    | 1    |
| 703  | 295356 | CIRCUIT BREAKER, 4 A     | 1    |
| 704  | 295368 | PROTECTOR, motor start   | 1    |
| 705  | 295275 | CONTACT, auxiliary; SPDT | 1    |

**460V, 3 Phase Models 295506, 295513, 295523 (9 kW Heaters)**

| Ref. | Part   | Description              | Qty. |
|------|--------|--------------------------|------|
| 701  | 295350 | CIRCUIT BREAKER, 25 A    | 2    |
| 702  | 295351 | CIRCUIT BREAKER, 16 A    | 1    |
| 703  | 295356 | CIRCUIT BREAKER, 4 A     | 1    |
| 704  | 295368 | PROTECTOR, motor start   | 1    |
| 705  | 295275 | CONTACT, auxiliary; SPDT | 1    |

# Electrical Components

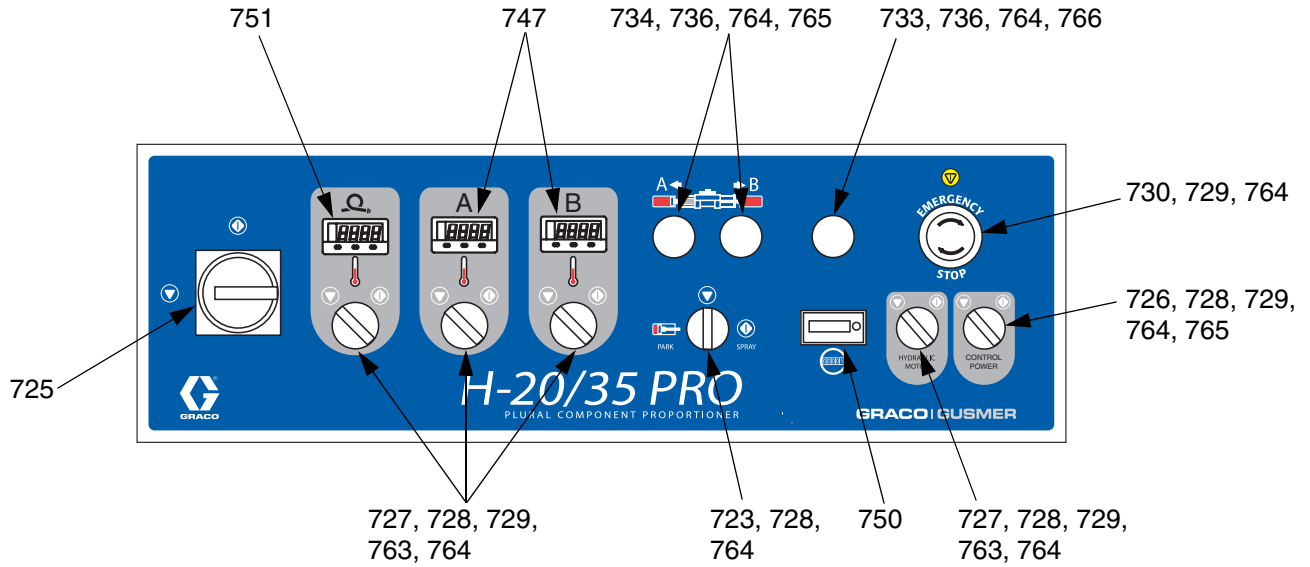

Front of Machine

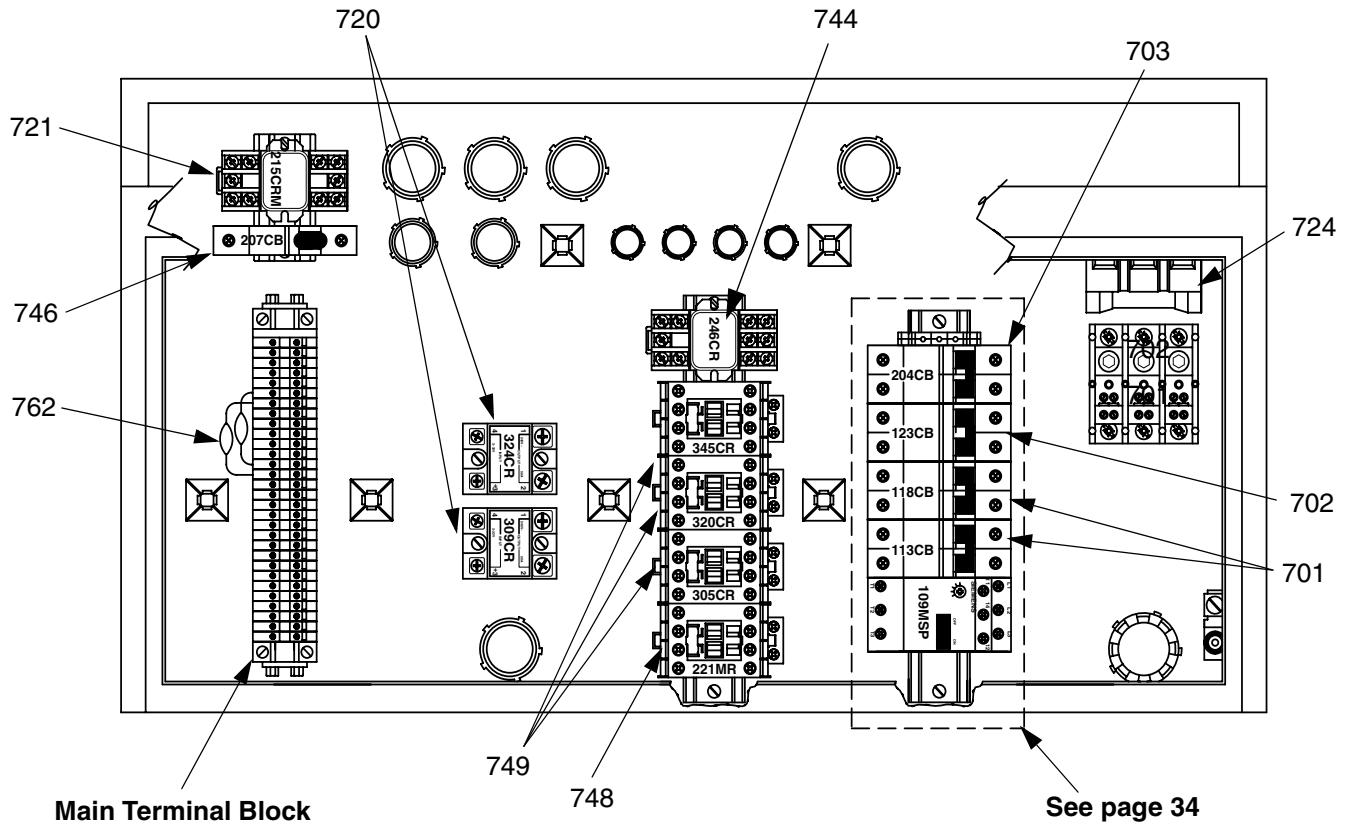

Main Terminal Block

See page 34

Parts

| Ref. | Part   | Description   | Qty. | Ref.  | Part   | Description   | Qty. |
|------|--------|---|------|---|--------|---|------|
| 720  | 295205 | RELAY, solid state; 480V; 50 A                                      | 2    | 744   | 295255 | RELAY, latching; 120 Vac  | 1    |
| 721  | 295206 | RELAY, dpdt; 120 Vac  | 1    | 746   | 295257 | CIRCUIT BREAKER; 6 A  | 1    |
| 723★ |        | SWITCH, selector, 3 position<br>(Kit 288630)                        | 1    | 747   | 296776 | CONTROL, temperature, A/B<br>heaters  | 2    |
| 724  | 295209 | DISCONNECT, main power; 100 A                                       | 1    | 748   | 120656 | CONTROL, power, 1 phase   | 1    |
| 725  | 295210 | SWITCH, main power on/off   | 1    |   | 295359 | CONTROL, power, 3 phase   | 1    |
| 726★ |        | SWITCH, selector, A/B; yellow<br>(Kit 288625)                       | 1    | 749   | 296824 | CONTROL, power  | 3    |
| 727★ |        | SWITCH, selector, A/B; green<br>(Kit 288624)                        | 4    | 750   | 296825 | COUNTER, digital  | 1    |
| 728★ |        | BLOCK, switch, normally open (Kits<br>288624, 288625, and 288630)   | 7    | 751   | 296778 | CONTROL, temperature, hose<br>heater  | 1    |
| 729★ |        | BLOCK, switch, normally closed<br>(Kits 288524, 288625, and 288631) | 6    | 762   | 295280 | CAPACITOR, with wires   | 2    |
| 730★ |        | SWITCH, push button, emergency<br>stop; red (Kit 288631)            | 1    | 763★  |        | LED; green (Kit 288624)   | 1    |
| 731  | 295216 | DIN CONNECTOR, pressure<br>switch                                   | 2    | 764★  |        | LATCH, mounting (Kits 288624,<br>288625, 288626, 288627, 288630,<br>and 288631) | 1    |
| 733★ |        | LENS,;clear (Kit 288627)  | 1    | 765★  |        | LED; yellow (Kits 288625 and<br>288627)   | 1    |
| 734★ |        | LENS; amber (Kit 288626)  | 2    | 766★  |        | LED; white (Kit 288626)   | 1    |
| 736★ |        | LIGHT, pilot, without lens (Kits<br>288626 and 288627)              | 3    | ★ Part not for individual sale. Available only in kits. See<br>kit descriptions on this page to order the correct<br>replacement kit. |        |   |      |

**Kit 288624 - Hydraulic Motor Switch**

**Ref. Description**

|     |                                |
|-----|--------------------------------|
| 763 | LED, green                     |
| 727 | SWITCH, selector, A/B; green   |
| 764 | LATCH, mounting                |
| 728 | BLOCK, switch, normally open   |
| 729 | BLOCK, switch, normally closed |

**Kit 288625 - Power Control Switch**

**Ref. Description**

|     |                                |
|-----|--------------------------------|
| 765 | LED, yellow                    |
| 726 | SWITCH, selector, A/B; yellow  |
| 764 | LATCH, mounting                |
| 728 | BLOCK, switch, normally open   |
| 729 | BLOCK, switch, normally closed |

**Kit 288626 - Pump Direction Light (Amber)**

**Ref. Description**

|     |                            |
|-----|----------------------------|
| 766 | LED                        |
| 764 | LATCH, mounting            |
| 736 | LIGHT, pilot; without lens |
| 733 | LENS                       |

**Kit 288627 - Power Display Light (Clear)**

**Ref. Description**

|     |                            |
|-----|----------------------------|
| 765 | LED                        |
| 764 | LATCH, mounting            |
| 736 | LIGHT, pilot; without lens |
| 734 | LENS                       |

**Kit 288630 - Stroke Switch**

**Ref. Description**

|     |                              |
|-----|------------------------------|
| 764 | LATCH, mounting              |
| 728 | BLOCK, switch, normally open |
| 723 | SWITCH, selector, 3 position |

**Kit 288631 - Emergency Stop Switch**

**Ref. Description**

|     |  |
|-----|--|
| 764 | LATCH, mounting                            |
| 729 | BLOCK, switch, normally closed             |
| 730 | SWITCH, pushbutton, emergency<br>stop; red |



A series of horizontal lines for writing, consisting of 25 evenly spaced lines extending across the width of the page.

# Electrical Schematics

## 230V, 1 Phase, sheet 1

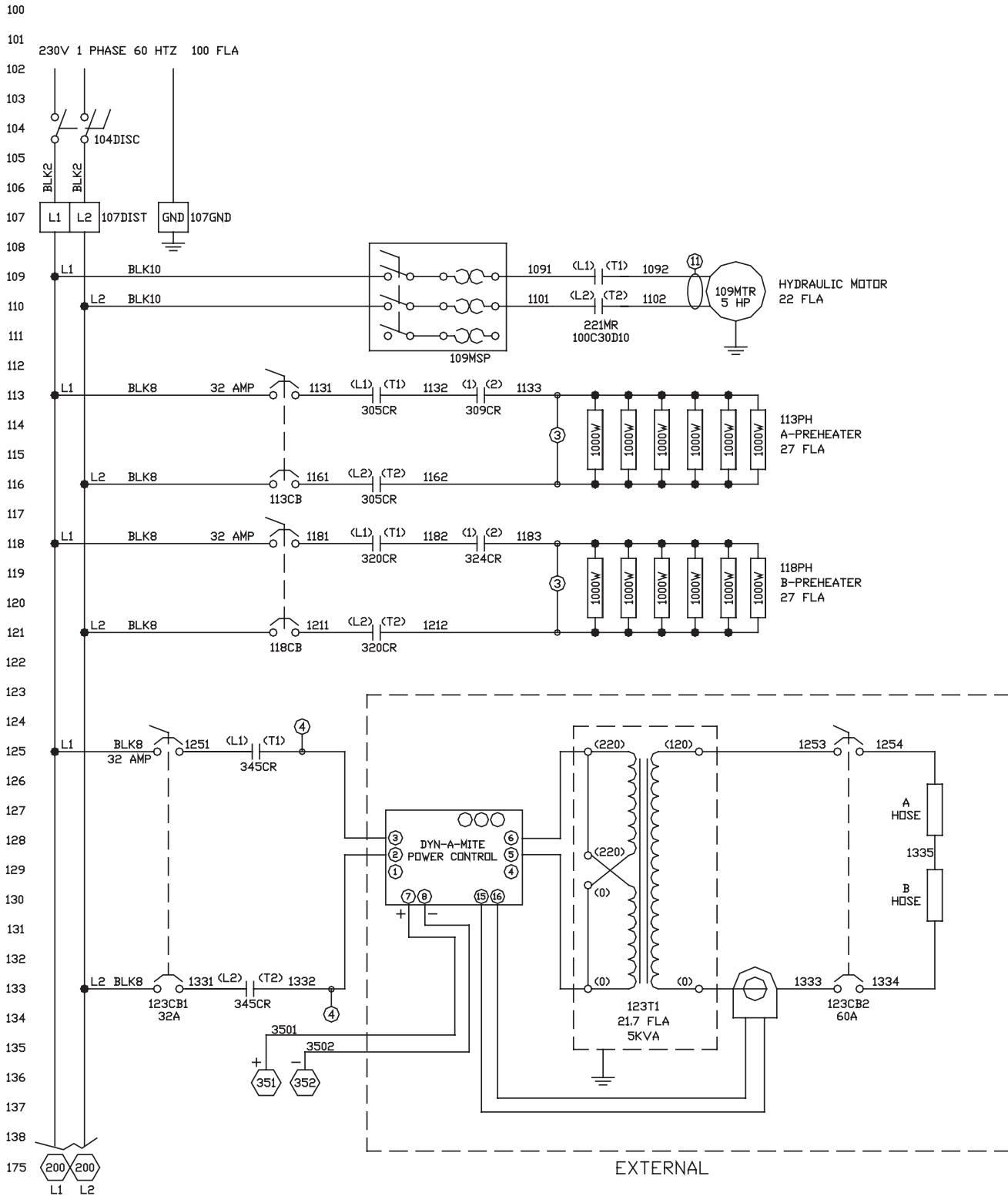

230V, 1 Phase, sheet 2

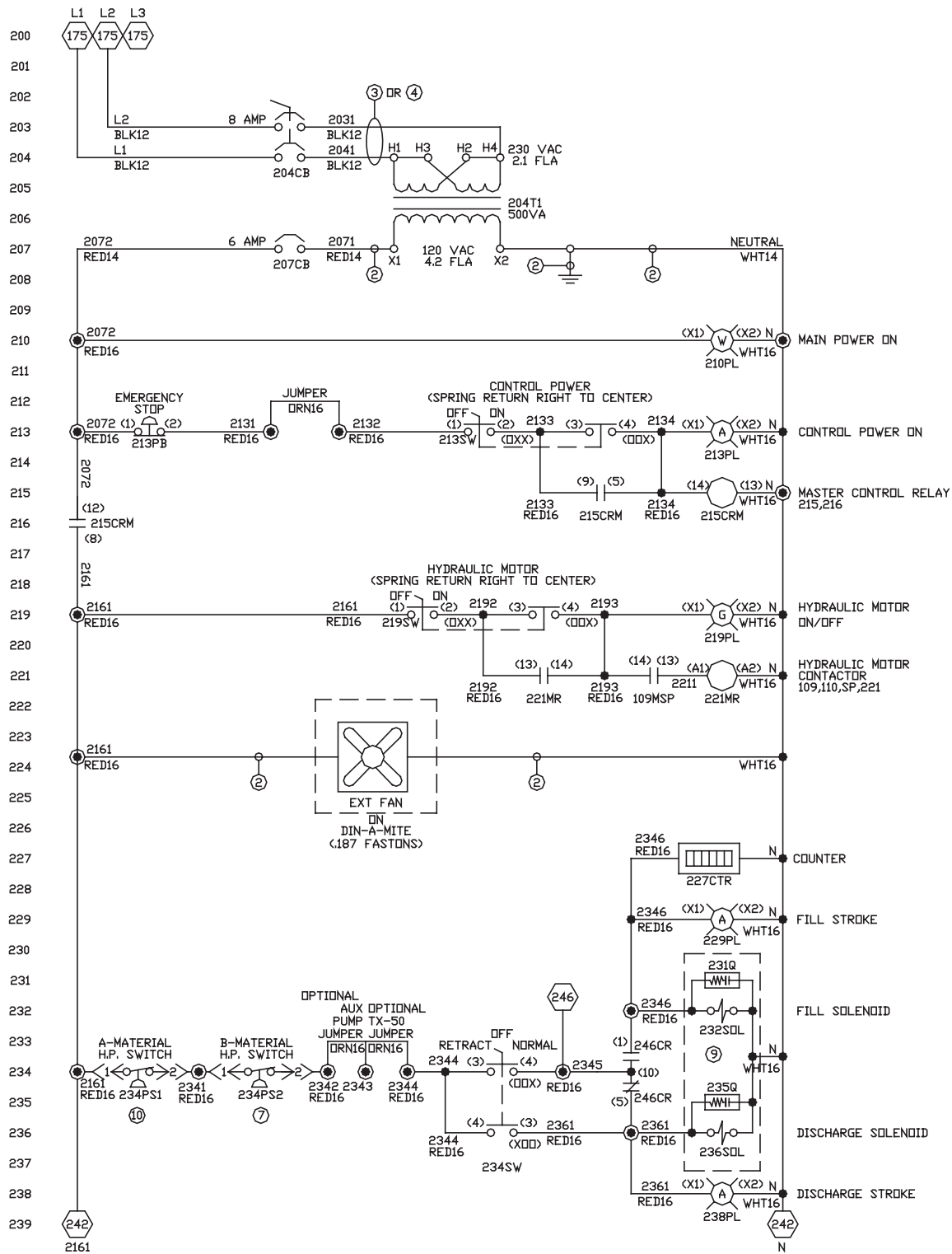

### 230V, 1 Phase, sheet 3

For final sheet of this schematic, see page 59.

240  
241  
242  
243  
244  
245  
246  
247  
248  
249  
250  
251  
252  
253  
254  
255  
256  
257  
258  
259  
260  
261  
262  
263  
264  
265  
266  
267  
268  
269  
270  
271  
272  
273  
274  
275  
276  
277  
278  
279

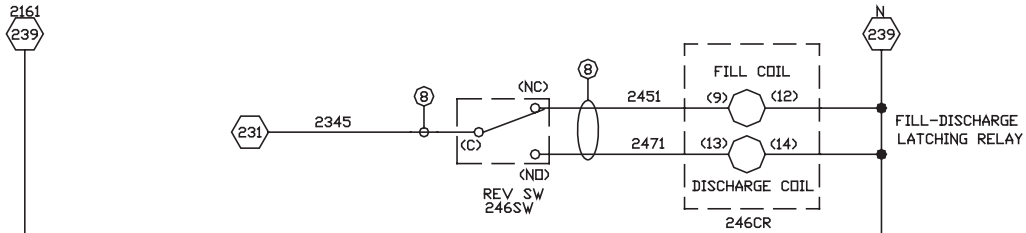

|   |      |   |
|---|------|---|
| ○ | 2072 | ○ |
| ○ | 2161 | ○ |
| ○ | 2161 | ○ |
| ○ | 2161 | ○ |
| ○ | N    | ○ |
| ○ | N    | ○ |
| ○ | N    | ○ |
| ○ | 2131 | ○ |
| ○ | 2132 | ○ |
| ○ | 2133 | ○ |
| ○ | 2134 | ○ |
| ○ | 2192 | ○ |
| ○ | 2193 | ○ |
| ○ | 2341 | ○ |
| ○ | 2342 | ○ |
| ○ | 2343 | ○ |
| ○ | 2344 | ○ |
| ○ | 2345 | ○ |
| ○ | 2346 | ○ |
| ○ | 2361 | ○ |
| ○ | 3034 | ○ |
| ○ | 3035 | ○ |
| ○ | 3036 | ○ |
| ○ | 3184 | ○ |
| ○ | 3185 | ○ |
| ○ | 3186 | ○ |
| ○ | 3431 | ○ |
| ○ | 3432 | ○ |
| ○ | 3501 | ○ |
| ○ | 3502 | ○ |

**WARNING:**  
DO NOT USE ANY TX50 THAT  
HAS A SERIAL NUMBER BELOW  
PRO800 - CONTACT GRACO  
CORPORATION FOR  
IMPORTANT INFORMATION.

TERMINAL LAYOUT





230V, 3 Phase, sheet 1

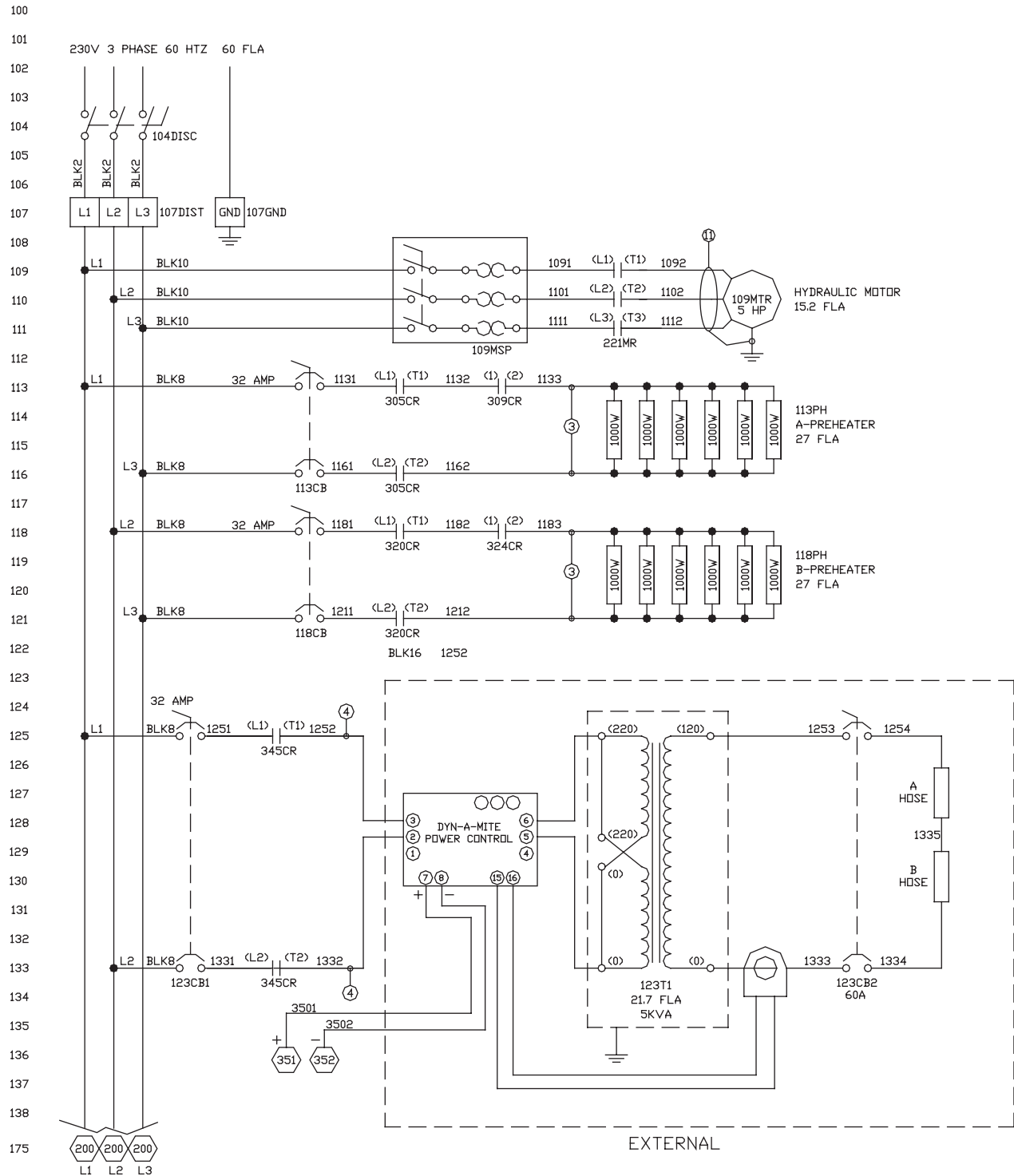

230V, 3 Phase, sheet 2

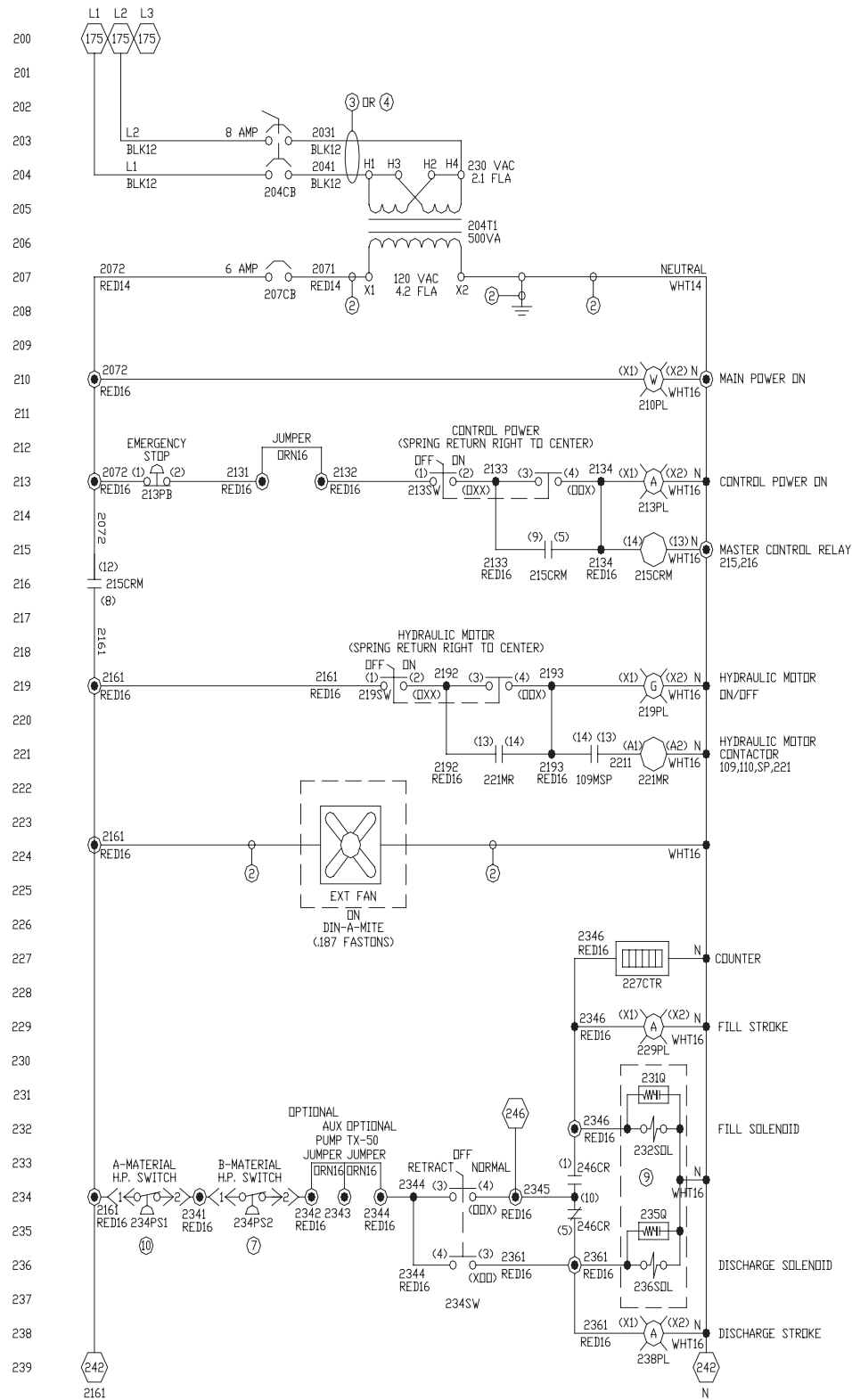

### 230V, 3 Phase, sheet 3

For final sheet of this schematic, see page 59.

240  
241  
242  
243  
244  
245  
246  
247  
248  
249  
250  
251  
252  
253  
254  
255  
256  
257  
258  
259  
260  
261  
262  
263  
264  
265  
266  
267  
268  
269  
270  
271  
272  
273  
274  
275  
276  
277  
278  
279

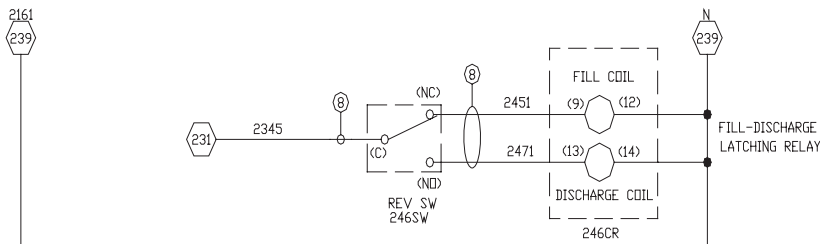

|   |      |   |
|---|------|---|
| o | 2072 | o |
| o | 2161 | o |
| o | 2161 | o |
| o | 2161 | o |
| o | N    | o |
| o | N    | o |
| o | N    | o |
| o | 2131 | o |
| o | 2132 | o |
| o | 2133 | o |
| o | 2134 | o |
| o | 2192 | o |
| o | 2193 | o |
| o | 2341 | o |
| o | 2342 | o |
| o | 2343 | o |
| o | 2344 | o |
| o | 2345 | o |
| o | 2346 | o |
| o | 2361 | o |
| o | 3034 | o |
| o | 3035 | o |
| o | 3036 | o |
| o | 3184 | o |
| o | 3185 | o |
| o | 3186 | o |
| o | 3431 | o |
| o | 3432 | o |
| o | 3501 | o |
| o | 3502 | o |

**WARNING:**  
DO NOT USE ANY TX50 THAT  
HAS A SERIAL NUMBER BELOW  
PRO800 - CONTACT GRACO  
CORPORATION FOR  
IMPORTANT INFORMATION.

TERMINAL LAYOUT

2161

N

### 230V, 3 Phase, 9 kW, sheet 1

100  
101  
102  
103  
104  
105  
106  
107  
108  
109  
110  
111  
112  
113  
114  
115  
116  
117  
118  
119  
120  
121  
122  
123  
124  
125  
126  
127  
128  
129  
130  
131  
132  
133  
134  
135  
136  
137  
138  
175

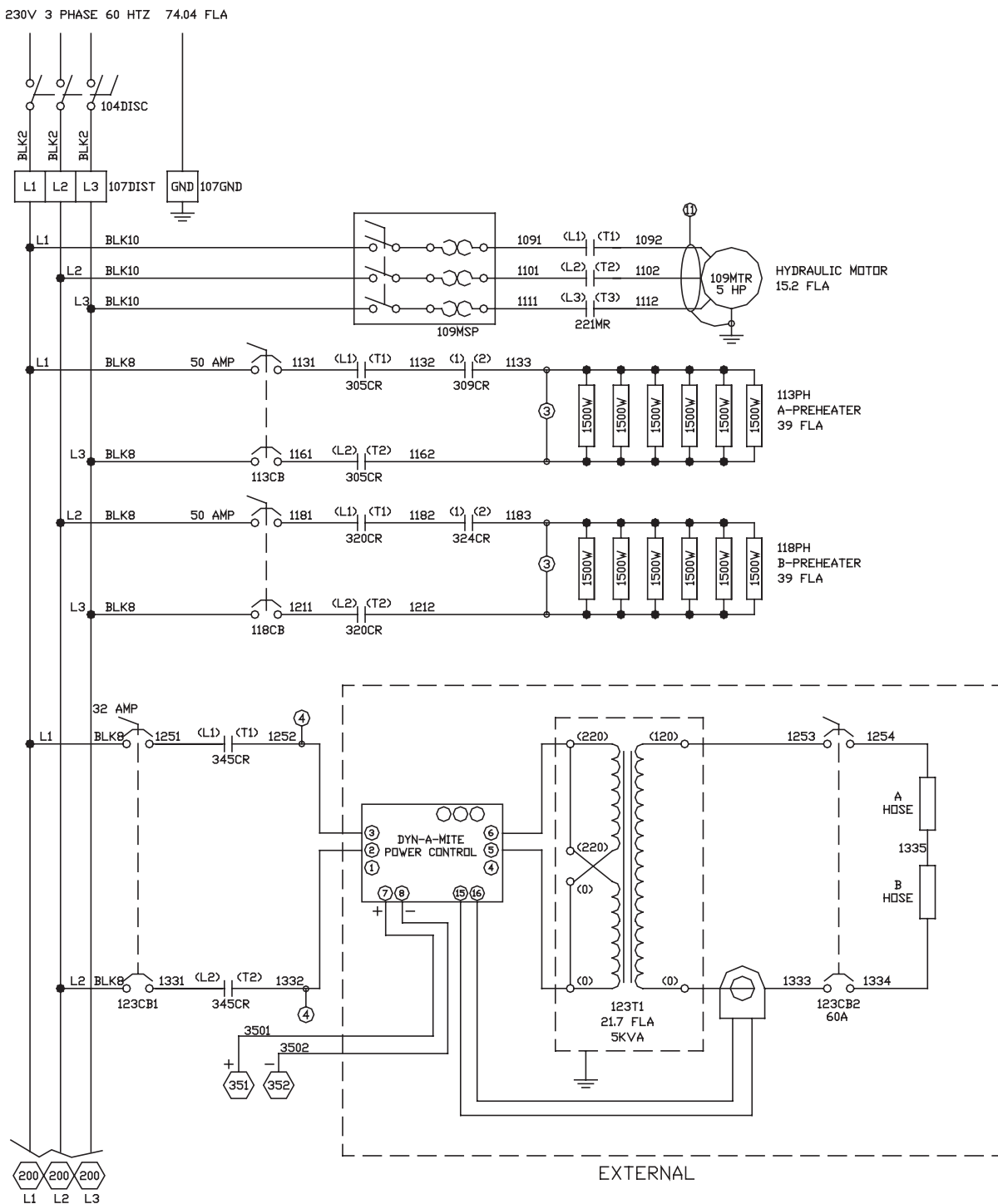

230V, 3 Phase, 9 kW, sheet 2

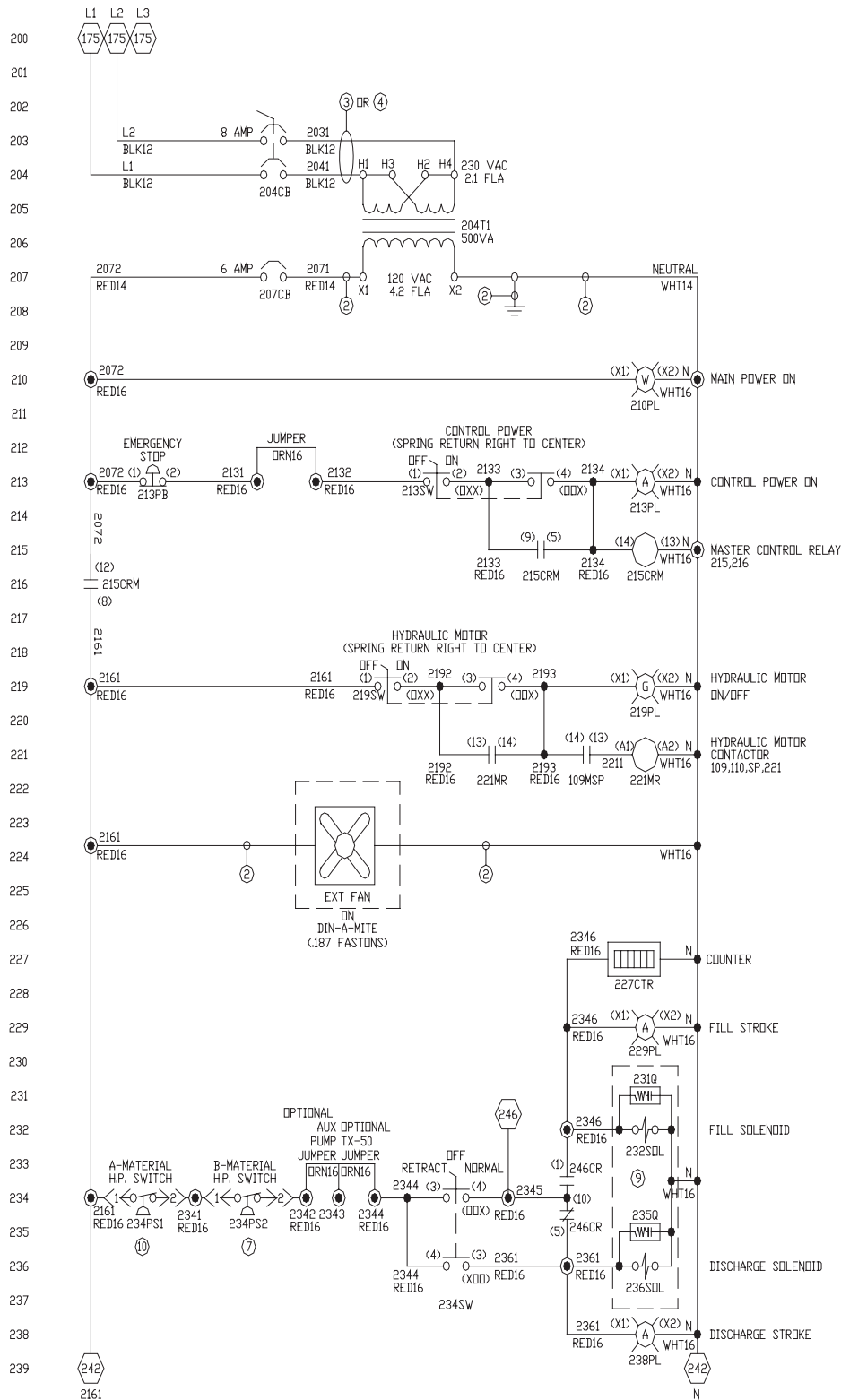

**230V, 3 Phase, 9 kW, sheet 3**

For final sheet of this schematic, see page 59.

240  
241  
242  
243  
244  
245  
246  
247  
248  
249  
250  
251  
252  
253  
254  
255  
256  
257  
258  
259  
260  
261  
262  
263  
264  
265  
266  
267  
268  
269  
270  
271  
272  
273  
274  
275  
276  
277  
278  
279

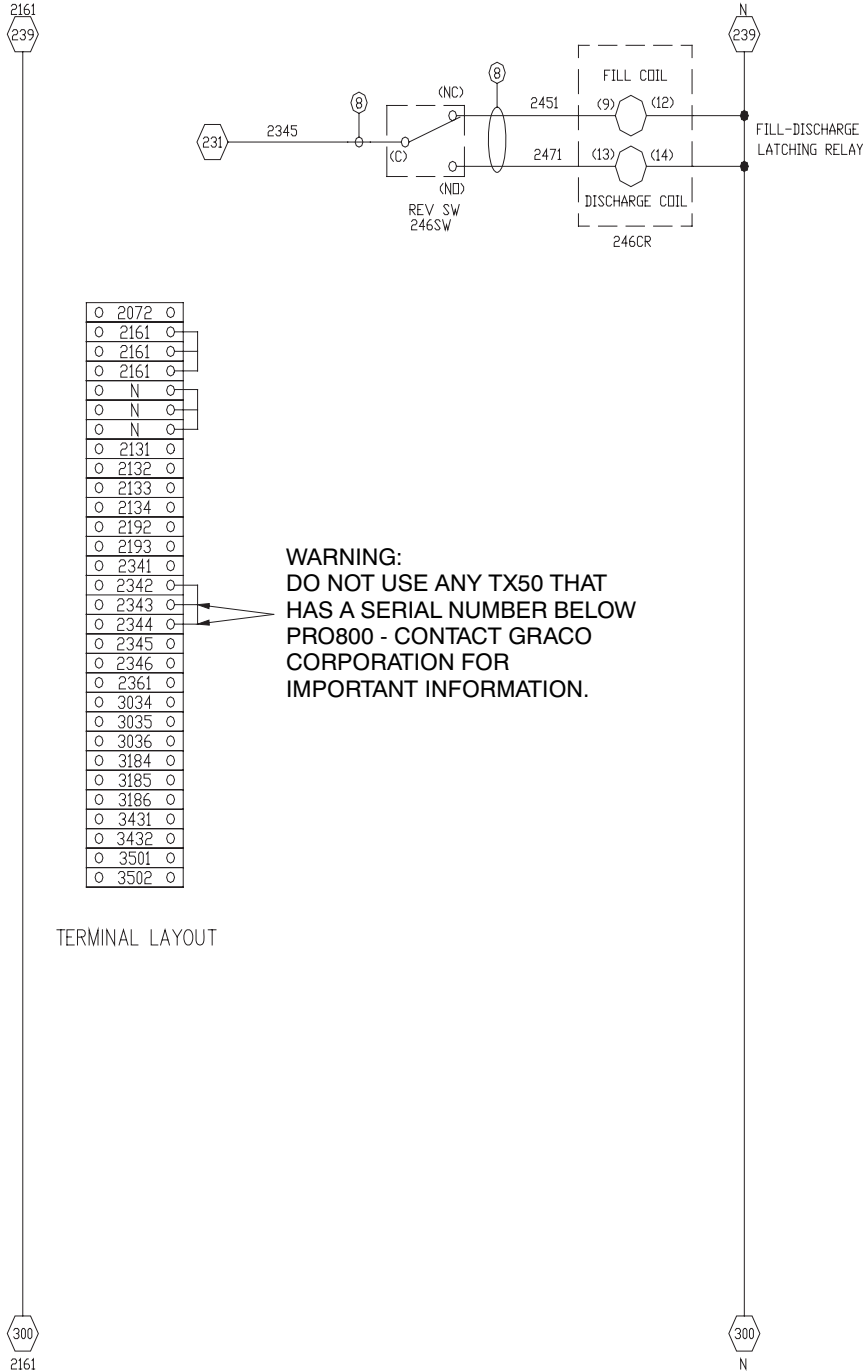

|   |      |   |
|---|------|---|
| o | 2072 | o |
| o | 2161 | o |
| o | 2161 | o |
| o | 2161 | o |
| o | N    | o |
| o | N    | o |
| o | N    | o |
| o | 2131 | o |
| o | 2132 | o |
| o | 2133 | o |
| o | 2134 | o |
| o | 2192 | o |
| o | 2193 | o |
| o | 2341 | o |
| o | 2342 | o |
| o | 2343 | o |
| o | 2344 | o |
| o | 2345 | o |
| o | 2346 | o |
| o | 2361 | o |
| o | 3034 | o |
| o | 3035 | o |
| o | 3036 | o |
| o | 3184 | o |
| o | 3185 | o |
| o | 3186 | o |
| o | 3431 | o |
| o | 3432 | o |
| o | 3501 | o |
| o | 3502 | o |

**WARNING:**  
DO NOT USE ANY TX50 THAT  
HAS A SERIAL NUMBER BELOW  
PRO800 - CONTACT GRACO  
CORPORATION FOR  
IMPORTANT INFORMATION.

TERMINAL LAYOUT

380V, 3 Phase, sheet 1

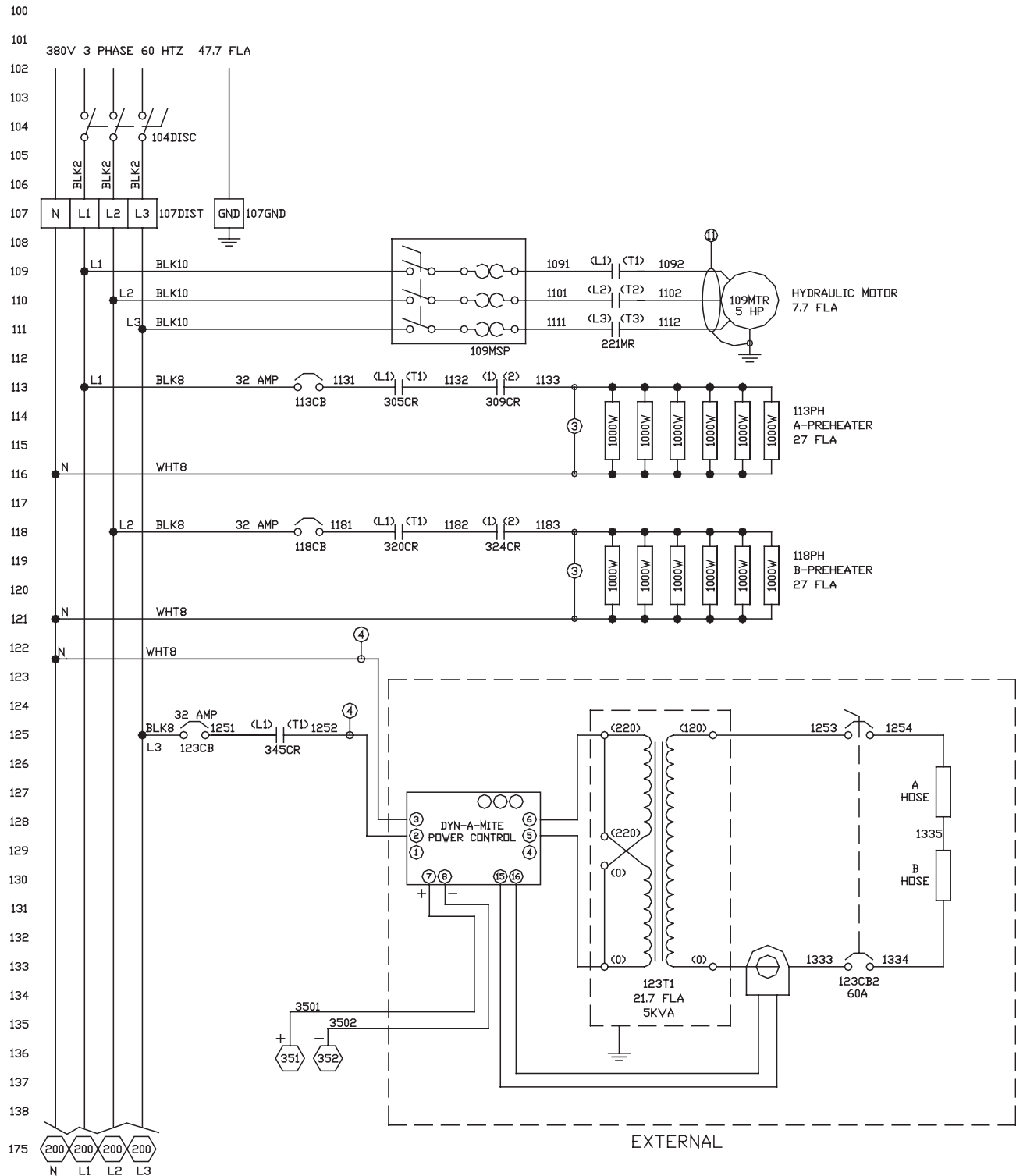

380V, 3 Phase, sheet 2

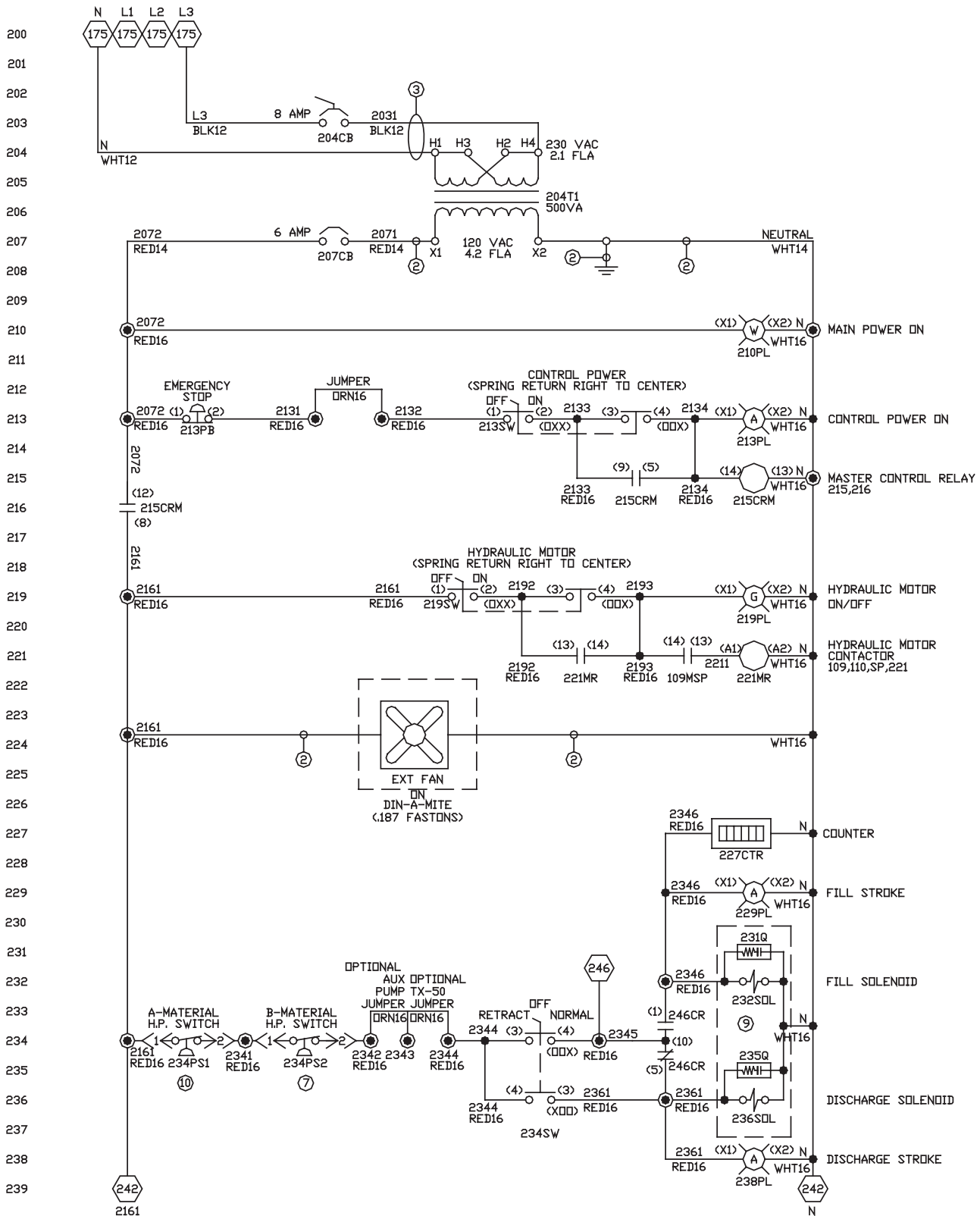



### 380V, 3 Phase, sheet 3

For final sheet of this schematic, see page 59.

240  
241  
242  
243  
244  
245  
246  
247  
248  
249  
250  
251  
252  
253  
254  
255  
256  
257  
258  
259  
260  
261  
262  
263  
264  
265  
266  
267  
268  
269  
270  
271  
272  
273  
274  
275  
276  
277  
278  
279

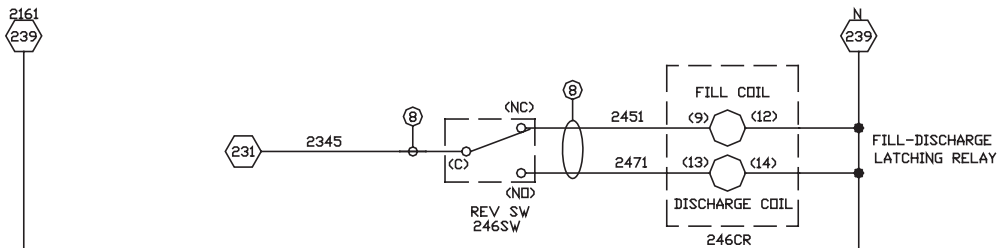

|   |      |   |
|---|------|---|
| ○ | 2072 | ○ |
| ○ | 2161 | ○ |
| ○ | 2161 | ○ |
| ○ | 2161 | ○ |
| ○ | N    | ○ |
| ○ | N    | ○ |
| ○ | N    | ○ |
| ○ | 2131 | ○ |
| ○ | 2132 | ○ |
| ○ | 2133 | ○ |
| ○ | 2134 | ○ |
| ○ | 2192 | ○ |
| ○ | 2193 | ○ |
| ○ | 2341 | ○ |
| ○ | 2342 | ○ |
| ○ | 2343 | ○ |
| ○ | 2344 | ○ |
| ○ | 2345 | ○ |
| ○ | 2346 | ○ |
| ○ | 2361 | ○ |
| ○ | 3034 | ○ |
| ○ | 3035 | ○ |
| ○ | 3036 | ○ |
| ○ | 3184 | ○ |
| ○ | 3185 | ○ |
| ○ | 3186 | ○ |
| ○ | 3431 | ○ |
| ○ | 3432 | ○ |
| ○ | 3501 | ○ |
| ○ | 3502 | ○ |

**WARNING:**  
DO NOT USE ANY TX50 THAT  
HAS A SERIAL NUMBER BELOW  
PRO800 - CONTACT GRACO  
CORPORATION FOR  
IMPORTANT INFORMATION.

TERMINAL LAYOUT

300  
2161

300  
N

### 380V, 3 Phase, 9 kW, sheet 1

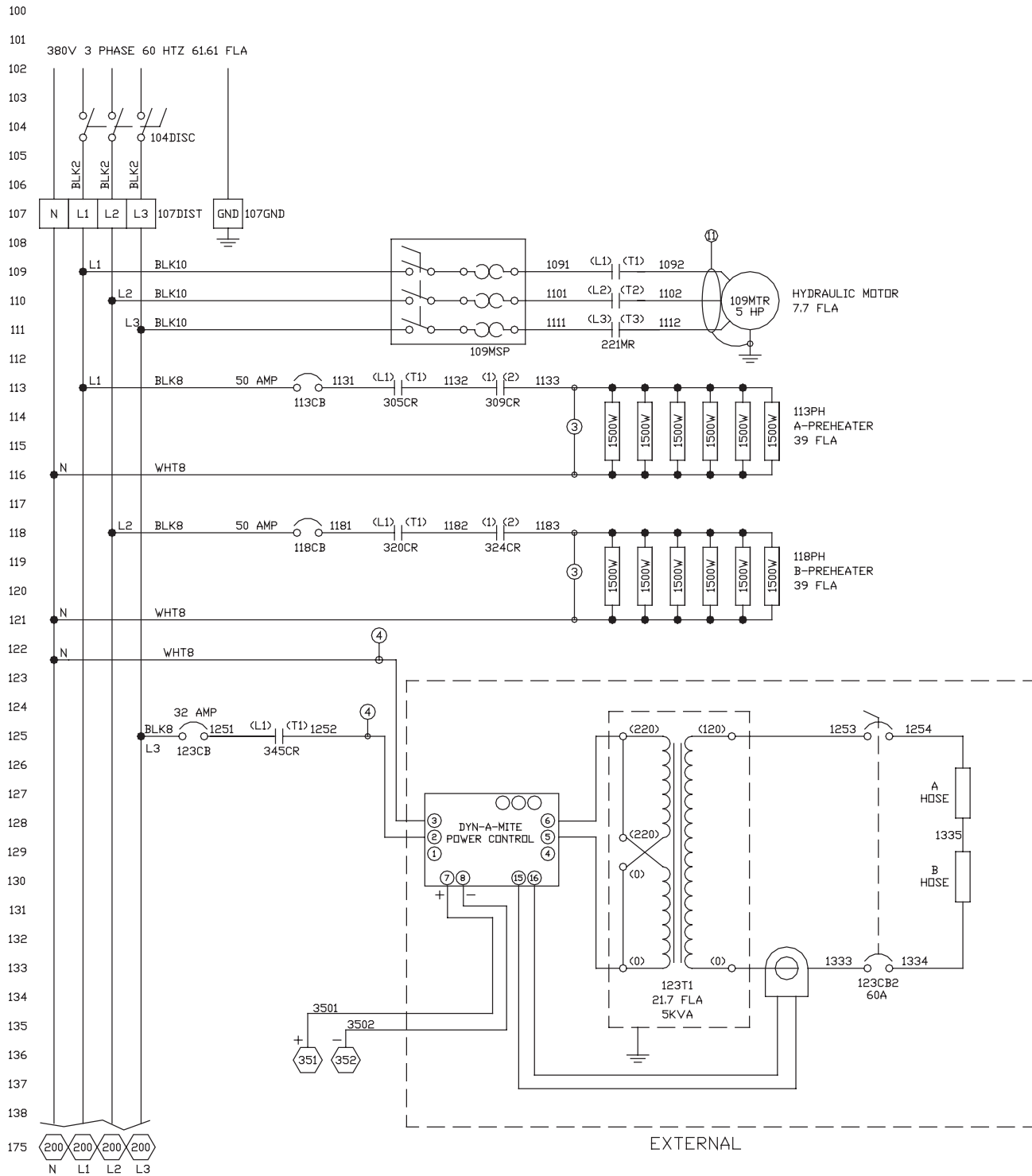

380V, 3 Phase, 9 kW, sheet 2

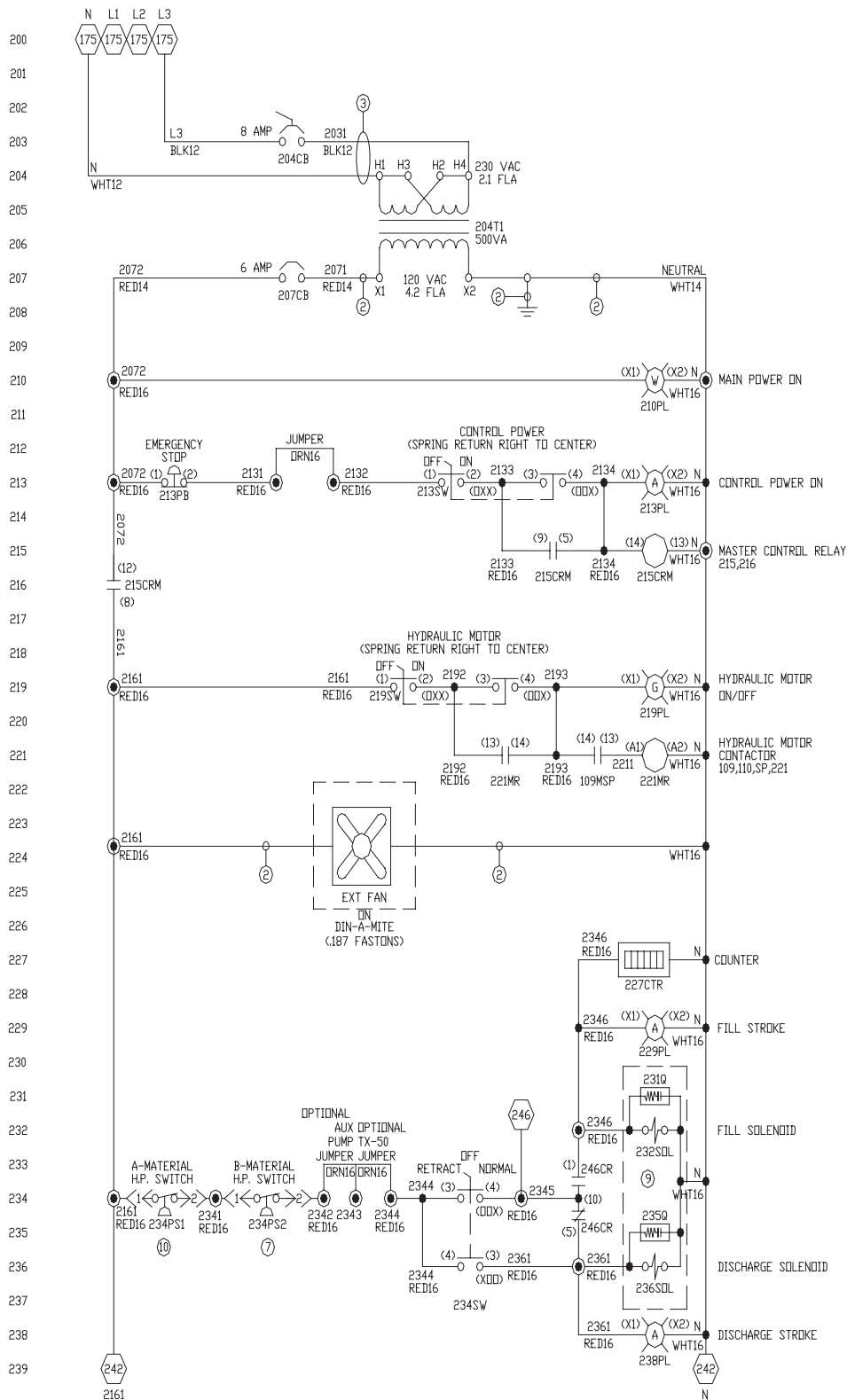

### 380V, 3 Phase, 9 kW, sheet 3

For final sheet of this schematic, see page 59.

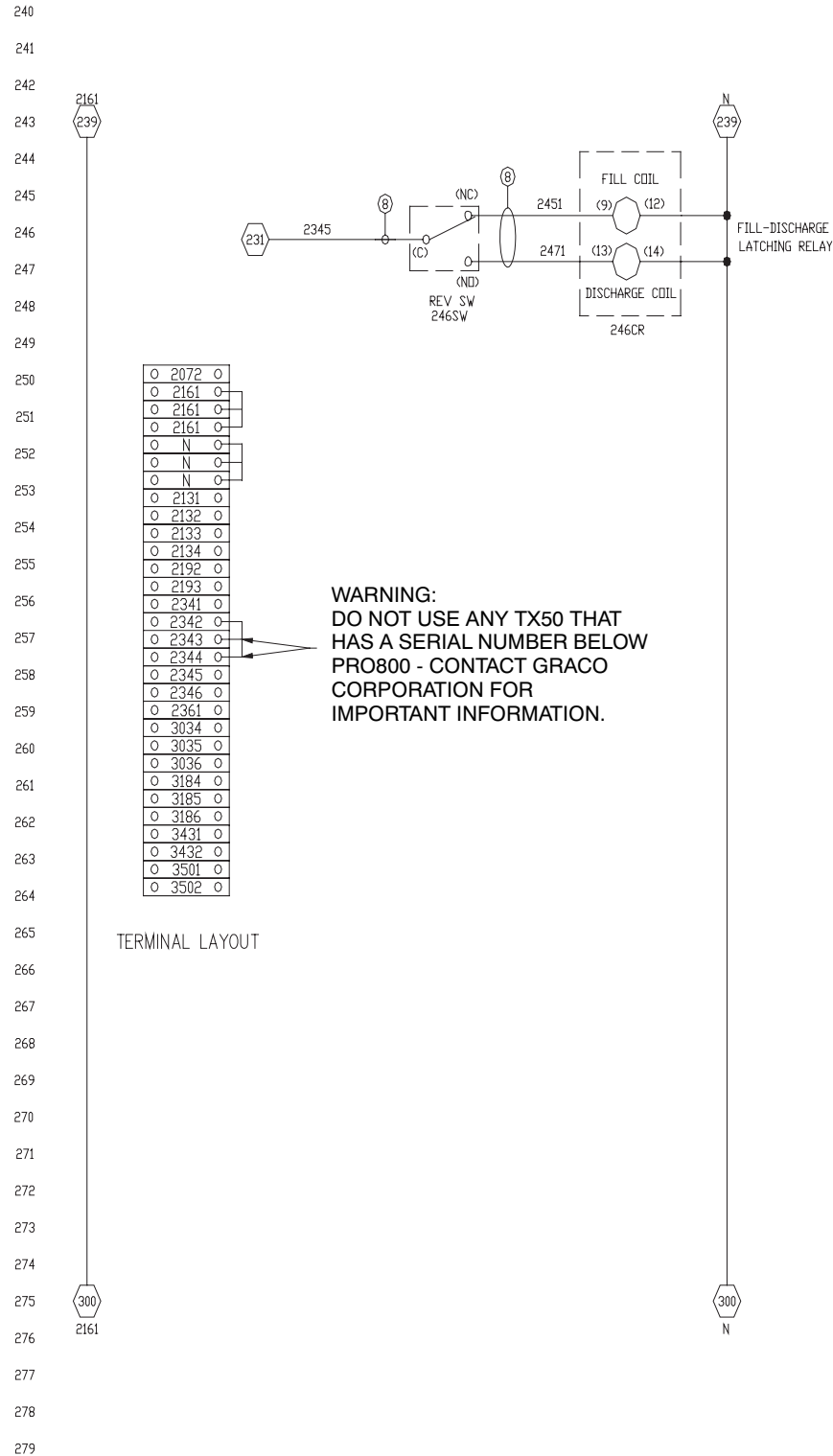

460V, 3 Phase, sheet 1

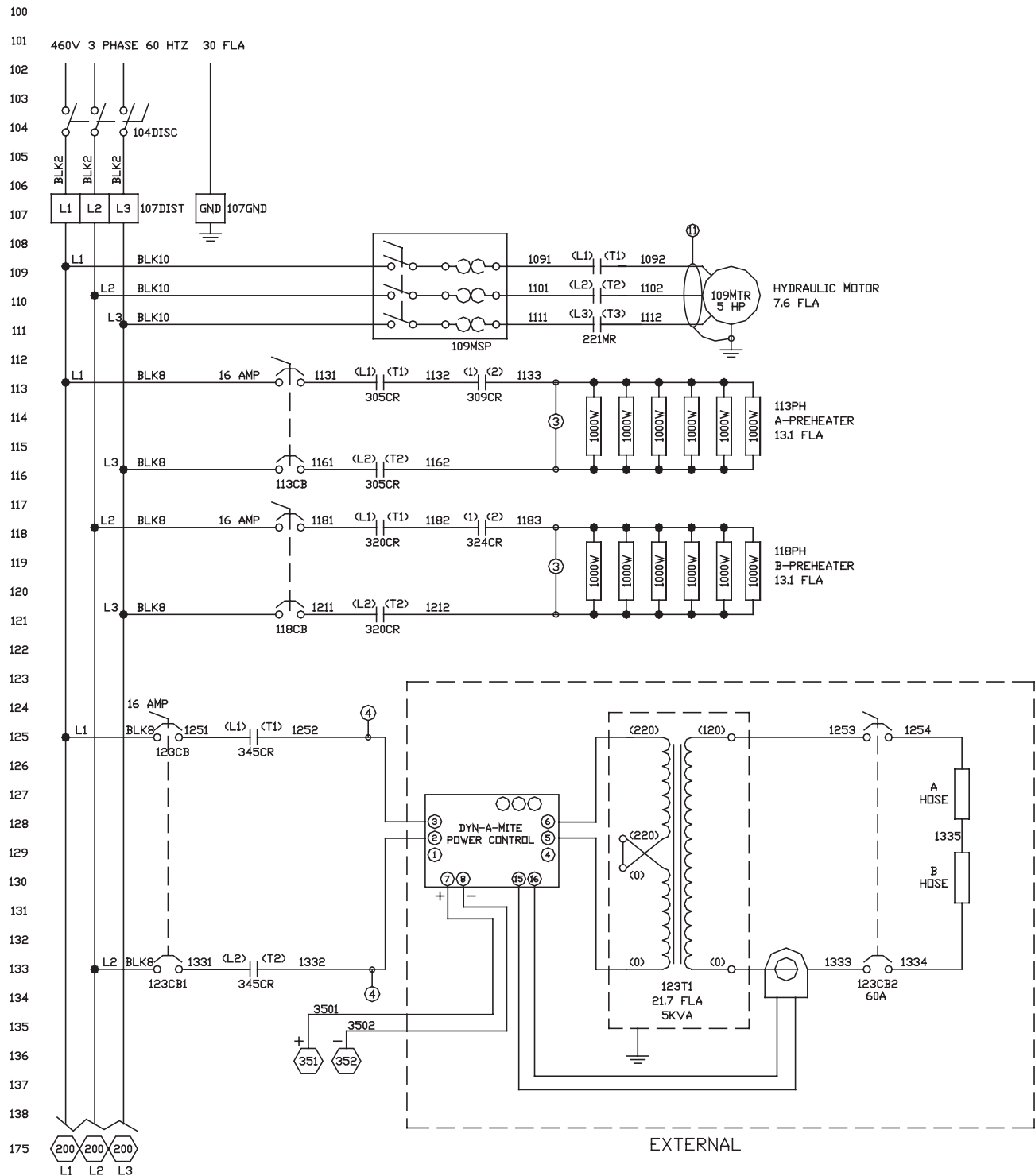

460V, 3 Phase, sheet 2

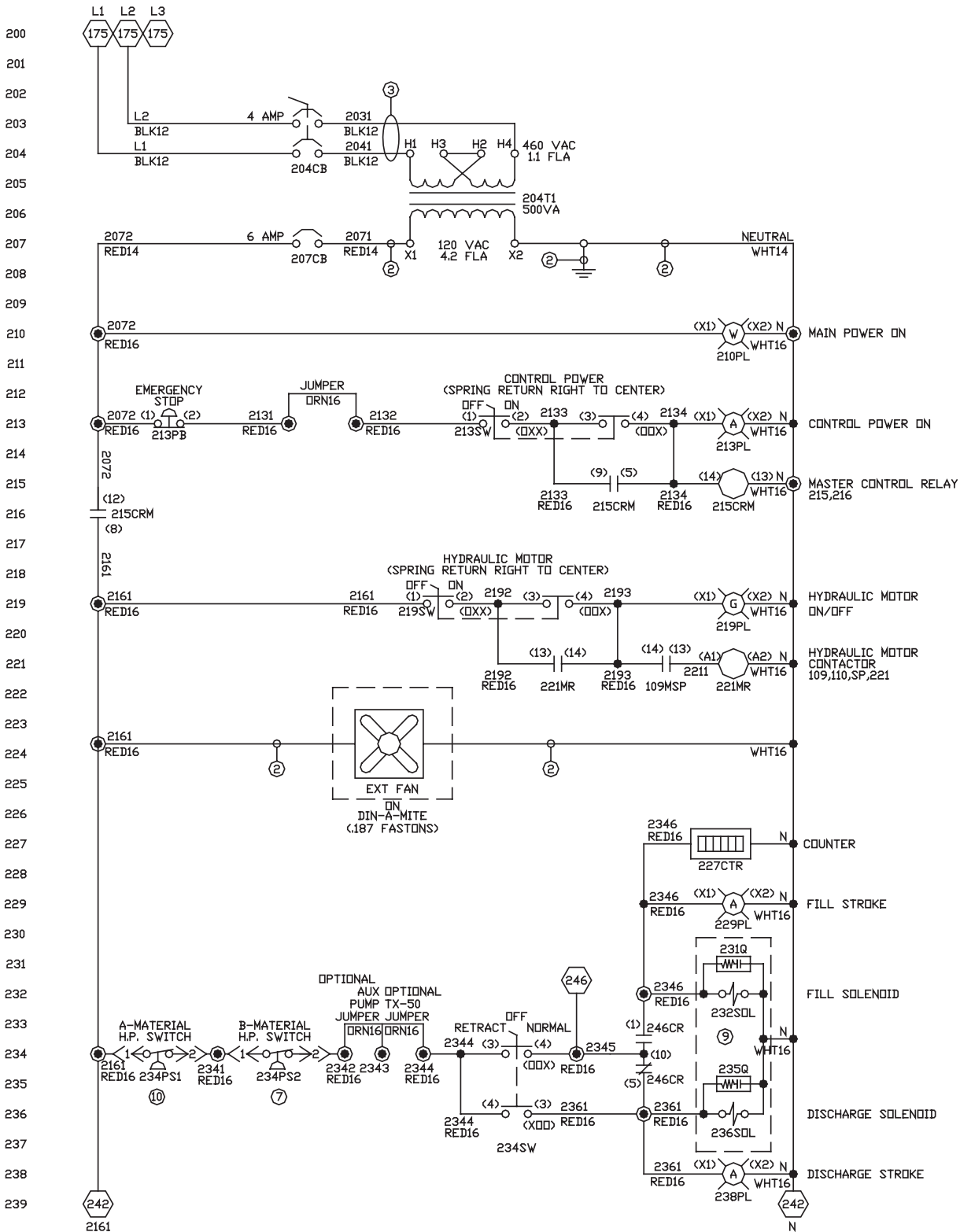

### 460V, 3 Phase, sheet 3

For final sheet of this schematic, see page 59.

240  
241  
242  
243  
244  
245  
246  
247  
248  
249  
250  
251  
252  
253  
254  
255  
256  
257  
258  
259  
260  
261  
262  
263  
264  
265  
266  
267  
268  
269  
270  
271  
272  
273  
274  
275  
276  
277  
278  
279

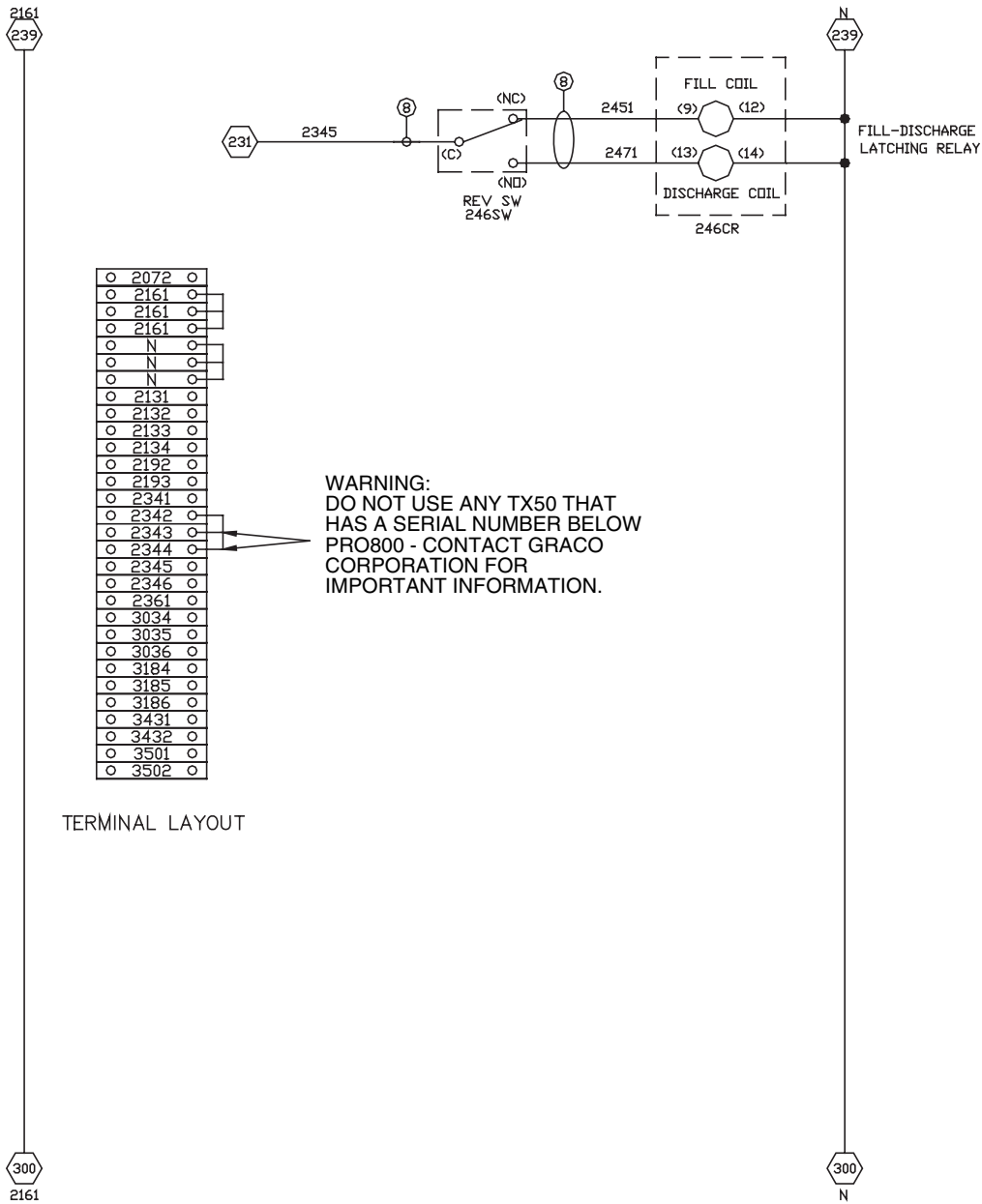

460V, 3 Phase, 9 kW, sheet 1

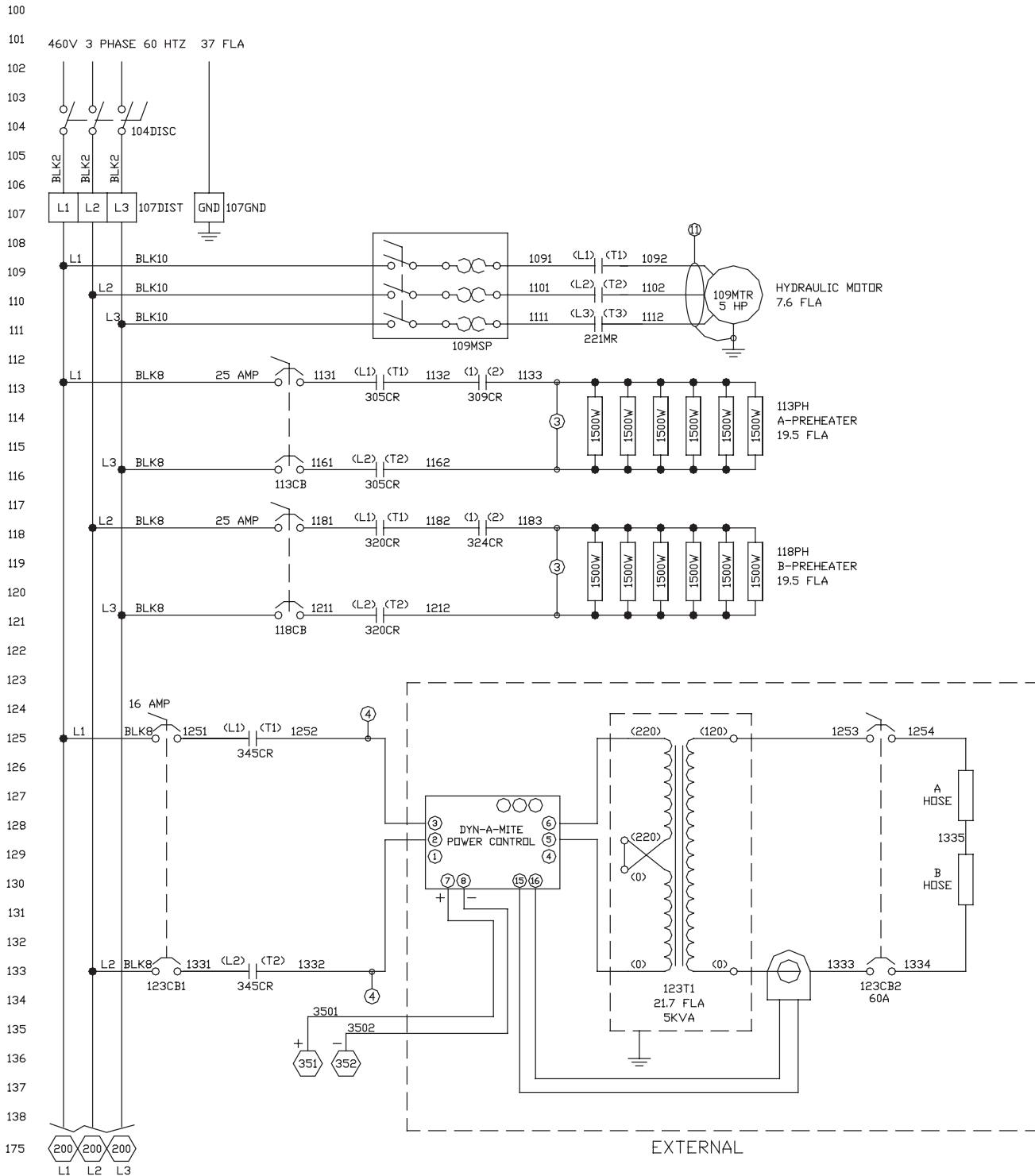



460V, 3 Phase, 9 kW, sheet 2

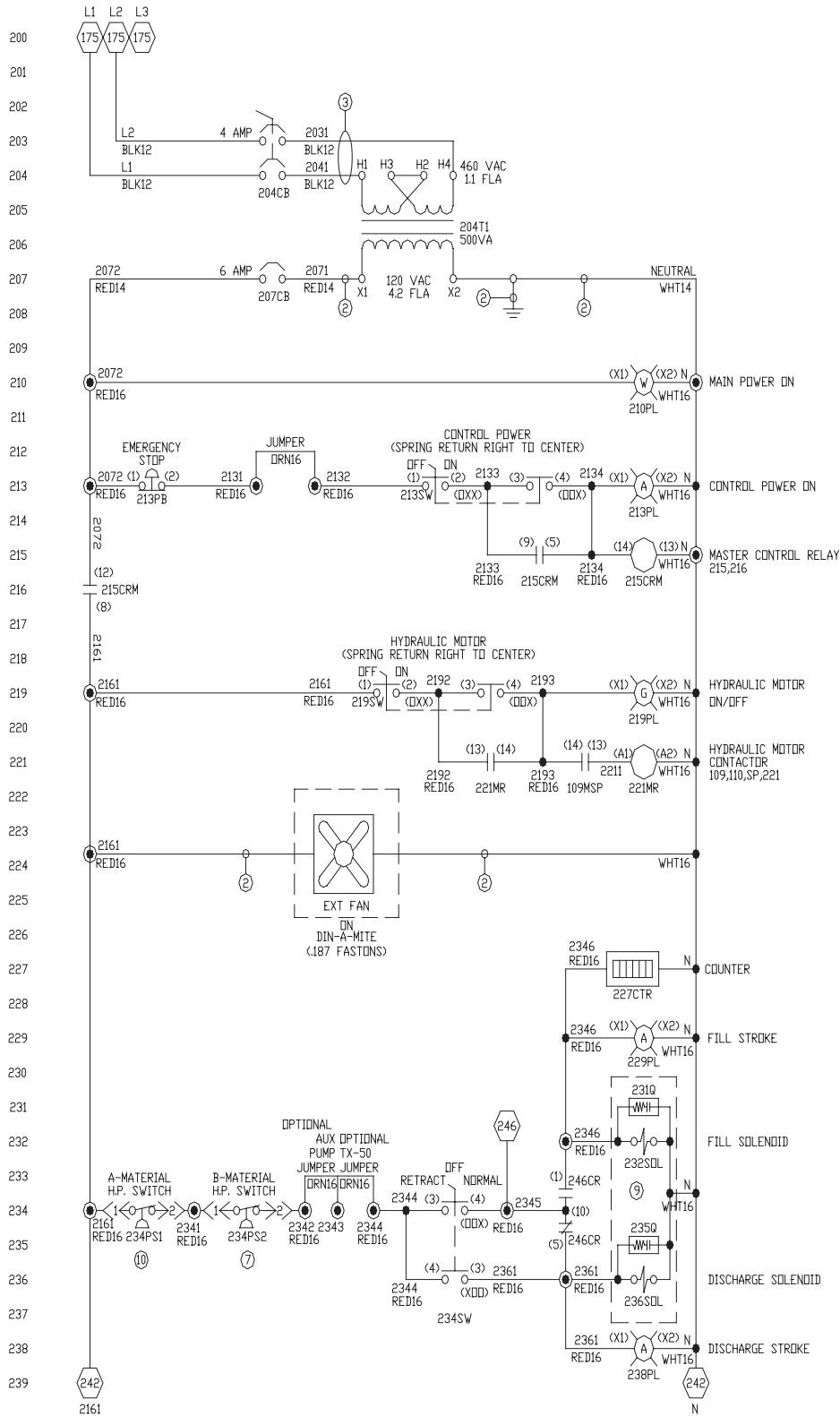

**460V, 3 Phase, 9 kW, sheet 3**

For final sheet of this schematic, see page 59.

240  
241  
242  
243  
244  
245  
246  
247  
248  
249  
250  
251  
252  
253  
254  
255  
256  
257  
258  
259  
260  
261  
262  
263  
264  
265  
266  
267  
268  
269  
270  
271  
272  
273  
274  
275  
276  
277  
278  
279

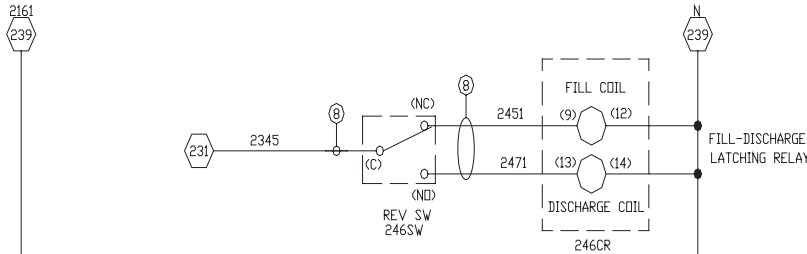

|   |      |   |
|---|------|---|
| o | 2072 | o |
| o | 2161 | o |
| o | 2161 | o |
| o | 2161 | o |
| o | N    | o |
| o | N    | o |
| o | N    | o |
| o | 2131 | o |
| o | 2132 | o |
| o | 2133 | o |
| o | 2134 | o |
| o | 2192 | o |
| o | 2193 | o |
| o | 2341 | o |
| o | 2342 | o |
| o | 2343 | o |
| o | 2344 | o |
| o | 2345 | o |
| o | 2346 | o |
| o | 2361 | o |
| o | 3034 | o |
| o | 3035 | o |
| o | 3036 | o |
| o | 3184 | o |
| o | 3185 | o |
| o | 3186 | o |
| o | 3431 | o |
| o | 3432 | o |
| o | 3501 | o |
| o | 3502 | o |

**WARNING:**  
DO NOT USE ANY TX50 THAT  
HAS A SERIAL NUMBER BELOW  
PRO800 - CONTACT GRACO  
CORPORATION FOR  
IMPORTANT INFORMATION.

TERMINAL LAYOUT



All Voltages, final sheet

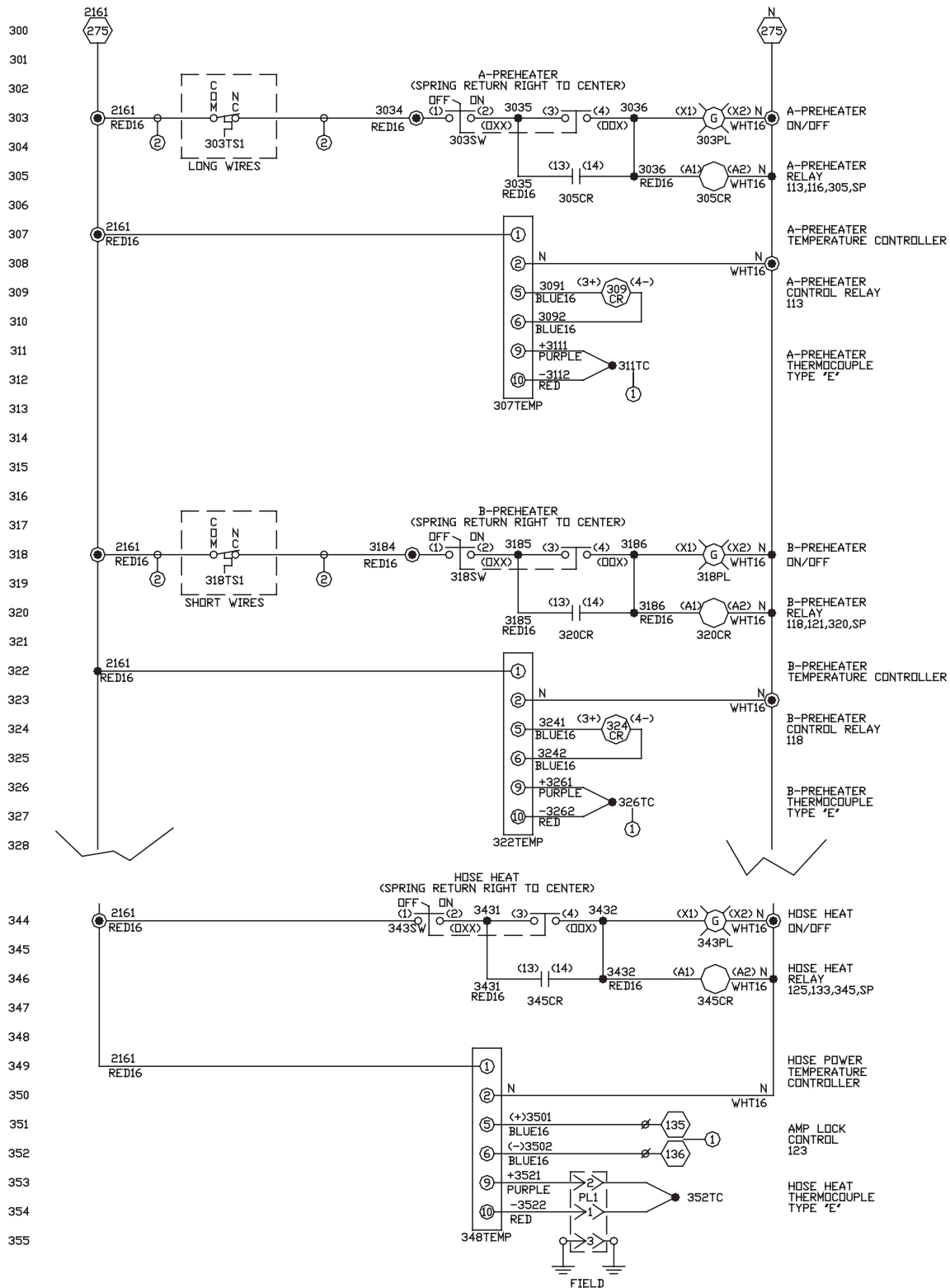



A series of horizontal lines for writing or drawing, starting from the pencil icon and extending across the page.

# Technical Data

## Category

Maximum working pressure

Maximum fluid temperature

Maximum output  
(may vary due to operating conditions)

Viscosity range

Maximum material inlet pressure

Voltage requirement (+/- 10%)

Amperage requirement

Total heater watts

Watts per heater

Hydraulic reservoir capacity

Recommended hydraulic fluid

Recommended hydraulic operating temperature

Maximum hydraulic operating temperature

Hydraulic operating pressure

Inlet filter size

Component B (resin) inlet

Component A (isocyanate) inlet

Maximum heated hose length

Height

Width

Depth

Weight

Wetted parts

## Data

*Model H20 Pro:* 2000 psi (13.8 MPa, 138 bar)  
*Model H25 Pro:* 2500 psi (17.2 MPa, 172 bar)  
*Model H35 Pro 104:* 2800 psi (19.3 MPa, 193 bar)  
*Model H35 Pro:* 3500 psi (24.0 MPa, 240 bar)

190°F (88°C)

*Model H20 Pro:* 38 lb/min (17.3 kg/min)  
*Model H25 Pro:* 31 lb/min (14.1 kg/min)  
*Model H35 Pro 104:* 27 lb/min (12.3 kg/min)  
*Model H35 Pro:* 22 lb/min (10.0 kg/min)

250-1500 centipoise

400 psi (2.7 MPa, 27 bar)

See **Models**, page 3

See **Models**, page 3

*Part Nos. 295500, 295501, 295503, 295505, 295507, 295508, 295510, 295512, 295514, 295515, 295516, 295517, 295520, and 295522:* 12000 W

*Part Nos. 295502, 295504, 295506, 295509, 295511, 295513, 295518, 295519, 295521, and 295523:* 18000 W

*Part Nos. 295500, 295501, 295503, 295505, 295507, 295508, 295510, 295512, 295514, 295515, 295516, 295517, 295520, and 295522:* 6000 W

*Part Nos. 295502, 295504, 295506, 295509, 295511, 295513, 295518, 295519, 295521, and 295523:* 9000 W

24 gal. (91 liters)

Mobil DTE 24 or 25

120°F (48°C)

160°F (71°C)

*Model H20 Pro:* 250-1050 psi (1.7-7.4 MPa, 17-74 bar)  
*Model H25 Pro:* 250-1300 psi (1.7-9.1 MPa, 17-91 bar)  
*Model H35 Pro 104:* 250-1300 psi (1.7-9.1 MPa, 17-91 bar)  
*Model H35 Pro:* 250-1225 psi (1.7-8.6 MPa, 17-86 bar)

80 mesh standard

3/4 npt(f)

1/2 npt(f)

410 ft (125 m)

47 in. (119 cm)

40 in. (102 cm)

22 in. (56 cm)

Empty: 385 lb (175 kg)

Filled: 735 lb (333 kg)

Carbon Steel, Stainless Steel, Chrome Aluminum, PTFE, Acetal, UHMWPE, fluoroelastomer

# Graco Standard Warranty

Graco warrants all equipment referenced in this document which is manufactured by Graco and bearing its name to be free from defects in material and workmanship on the date of sale to the original purchaser for use. With the exception of any special, extended, or limited warranty published by Graco, Graco will, for a period of twelve months from the date of sale, repair or replace any part of the equipment determined by Graco to be defective. This warranty applies only when the equipment is installed, operated and maintained in accordance with Graco's written recommendations.

This warranty does not cover, and Graco shall not be liable for general wear and tear, or any malfunction, damage or wear caused by faulty installation, misapplication, abrasion, corrosion, inadequate or improper maintenance, negligence, accident, tampering, or substitution of non-Graco component parts. Nor shall Graco be liable for malfunction, damage or wear caused by the incompatibility of Graco equipment with structures, accessories, equipment or materials not supplied by Graco, or the improper design, manufacture, installation, operation or maintenance of structures, accessories, equipment or materials not supplied by Graco.

This warranty is conditioned upon the prepaid return of the equipment claimed to be defective to an authorized Graco distributor for verification of the claimed defect. If the claimed defect is verified, Graco will repair or replace free of charge any defective parts. The equipment will be returned to the original purchaser transportation prepaid. If inspection of the equipment does not disclose any defect in material or workmanship, repairs will be made at a reasonable charge, which charges may include the costs of parts, labor, and transportation.

**THIS WARRANTY IS EXCLUSIVE, AND IS IN LIEU OF ANY OTHER WARRANTIES, EXPRESS OR IMPLIED, INCLUDING BUT NOT LIMITED TO WARRANTY OF MERCHANTABILITY OR WARRANTY OF FITNESS FOR A PARTICULAR PURPOSE.**

Graco's sole obligation and buyer's sole remedy for any breach of warranty shall be as set forth above. The buyer agrees that no other remedy (including, but not limited to, incidental or consequential damages for lost profits, lost sales, injury to person or property, or any other incidental or consequential loss) shall be available. Any action for breach of warranty must be brought within two (2) years of the date of sale.

**GRACO MAKES NO WARRANTY, AND DISCLAIMS ALL IMPLIED WARRANTIES OF MERCHANTABILITY AND FITNESS FOR A PARTICULAR PURPOSE, IN CONNECTION WITH ACCESSORIES, EQUIPMENT, MATERIALS OR COMPONENTS SOLD BUT NOT MANUFACTURED BY GRACO.** These items sold, but not manufactured by Graco (such as electric motors, switches, hose, etc.), are subject to the warranty, if any, of their manufacturer. Graco will provide purchaser with reasonable assistance in making any claim for breach of these warranties.

In no event will Graco be liable for indirect, incidental, special or consequential damages resulting from Graco supplying equipment hereunder, or the furnishing, performance, or use of any products or other goods sold hereto, whether due to a breach of contract, breach of warranty, the negligence of Graco, or otherwise.

## **FOR GRACO CANADA CUSTOMERS**

The Parties acknowledge that they have required that the present document, as well as all documents, notices and legal proceedings entered into, given or instituted pursuant hereto or relating directly or indirectly hereto, be drawn up in English. Les parties reconnaissent avoir convenu que la rédaction du présente document sera en Anglais, ainsi que tous documents, avis et procédures judiciaires exécutés, donnés ou intentés, à la suite de ou en rapport, directement ou indirectement, avec les procédures concernées.

# Graco Information

**TO PLACE AN ORDER**, contact your Graco distributor or call to identify the nearest distributor.

**Phone:** 612-623-6921 **or Toll Free:** 1-800-328-0211 **Fax:** 612-378-3505

*All written and visual data contained in this document reflects the latest product information available at the time of publication.  
Graco reserves the right to make changes at any time without notice.*

*This manual contains English. MM 311393*

**Graco Headquarters:** Minneapolis  
**International Offices:** Belgium, China, Japan, Korea

**GRACO INC. P.O. BOX 1441 MINNEAPOLIS, MN 55440-1441**

Copyright 2007, Graco Inc. is registered to I.S. EN ISO 9001

www.graco.com  
Revised 10/2008